



**AGENDA**  
**GREATER NAPLES FIRE RESCUE DISTRICT**  
**BOARD OF FIRE COMMISSIONERS MEETING**  
**February 13, 2018**

- I. Meeting Opened
- A. Pledge of Allegiance and Invocation
  - B. Line of Duty Deaths Reading and Moment of Silence
  - C. Approval, Additions and Deletions to the Agenda
  - D. Approval of the GNFD Board Minutes for January 9, 2018 1 - 4
  - E. Consent Agenda  
*All matters listed under this item are considered routine and action will be taken by one motion without separate discussion of each item; if discussion is desired by a member of the Board, that item(s) will be removed from the Consent Agenda and considered separately.*
    - 1. Treasurer Report 5 - 20
    - 2. Operations Section Report - Assistant Chief Sapp 21 - 28
    - 3. Administration and Finance Section Report - Deputy Director Bishop 29
    - 4. Planning Section Report - Deputy Director Martin 30 - 31
    - 5. Logistics Section Reports
      - a. Facilities Report– Deputy Chief McLaughlin 32
      - b. Training and Specials Operations Report- Deputy Chief Low 33
    - 6. Investigative Section Report - Deputy Chief Hanson 34 - 36
    - 7. Dispositions of Assets #18-004 – Deputy Chief McLaughlin 37
    - 8. At-A-Boys
      - a. Lt. John Bigica 38
  - F. Awards and Recognition
    - 1. Announcement Part-time Aaron Borowski to Full Time
    - 2. Completion of Probation: Administrative Assistant Tracey Caparrelli and Fire Fighter Temperilli
    - 3. 15 Year Service Award- Lt. Greg Baker
    - 4. FFCA Inspector of the Year- Lt. Inspector John Bigica
    - 5. Retirement Lt. Chris Ogden
  - G. Fire Chief’s Report - Chief Schuldt 39 - 42
  - H. Chapter 175 Firefighters’ Pension Plan - Chairman Arroyo
  - I. Local 2396 Report – President Trenton Mading 43
    - MDA Boot Drive February times and dates
    - February 23<sup>rd</sup> 3pm-6pm @ Pine Ridge Rd & Logan Blvd
    - February 24<sup>th</sup> 9am-1pm @ Vanderbilt Beach Rd & Logan Blvd



**AGENDA**  
**GREATER NAPLES FIRE RESCUE DISTRICT**  
**BOARD OF FIRE COMMISSIONERS MEETING**  
**February 13, 2018**

**II. OLD BUSINESS**

- A. Emergency Services Task Force - Commissioner Hemping
- B. Greater Naples/North Collier Collaboration Update- Chief Schuldt

**III. NEW BUSINESS**

- A. Squad 76- Commissioner Gerrity 44 - 47
- B. Ochopee Management Agreement- Commissioner Gerrity 48 - 74
- C. AIW - LMS Mitigations Strategy - Deputy Chief Alan McLaughlin 75 - 80
- D. AIW- FM Global Fire Prevention Grant Program- Deputy Chief Hanson 81
- E. AIW- 2018 Fire Prevention & Safety Grant- Deputy Chief Hanson 82 - 83
- F. AIW- Knox Key Secure Program- Deputy Chief Hanson 84 - 89
- G. AIW- Post Fire On-Scene Decontamination Kits -Deputy Chief Low 90
- H. AIW- Greater Naples Chamber of Commerce Internship Program- Chief Schuldt 91 - 92
- I. Public Comment on Items not listed on the Agenda
- J. Comments by Commissioners

**IV. ADJOURNMENT**

**Next Regular BOFC Meeting Tuesday March 13, 2018**



**MINUTES**  
**GREATER NAPLES FIRE RESCUE DISTRICT**  
**BOARD OF FIRE COMMISSIONERS MEETING**  
**January 9, 2018**

**MEETING OPENED**

Chairman Cross called to order the regular meeting of the Greater Naples Fire Rescue District's Board of Fire Commissioners meeting at 5:30pm., on January 9, 2018 at Administrative Headquarters. Present were Chairman Cross, Commissioners Page, Boyer, Hemping, Stedman, Henning, Gerrity and Cottiers. Executive Staff in attendance; Fire Chief Kingman Schuldt, Assistant Chief Sapp, Deputy Chief's Low, Hanson, and McLaughlin and Deputy Directors Bishop and Martin, Battalion Chief Davenport. Staff in attendance: Nicole Chesser. Public in attendance: Trenton Madding, Brandon Bunting, Jarrett Cotter, Gorge Danz, Chiefs Choate and Cunningham from Immokalee Fire, and Director D'Angelo from North Collier Fire.

**A. Pledge of Allegiance and Invocation**

Chairman Page opened the meeting with the Pledge of Allegiance followed by the invocation by Commissioner Gerrity.

**B. Line of Duty Deaths Reading and Moment of Silence**

Chief Schuldt reported there were a total of 12 Firefighter fatalities for the month of December, bringing the total for 2017 to 93, followed by a moment of silence. Commissioner Page ask the Chief to forward the details surrounding the fatalities.

**C. Additions and Deletions to the Agenda**

No Additions or deletions from staff. Commissioner Hemping moved to accept the Agenda as presented. Commissioner Boyer seconded. Motion passed 7-0

**D. Approval of the GNFD Board Minutes for December 12, 2017**

Commissioner Hemping moved to accept the minutes as presented. Commissioner Boyer seconded the motion. Motion Passed 7-0

**E. Consent Agenda**

Commissioner Page moved to approve the consent agenda as presented. Commissioner Boyer seconded the motion. Motion passed 7-0.

1. Treasurer's Report
2. Operations Section Report – Assistant Chief Sapp
3. Administration and Finance Section Report – Deputy Director Bishop
4. Planning Section Report – Deputy Chief Martin
5. Logistics Section Report – Deputy Chief McLaughlin
  - a. Facilities Report – Deputy Chief McLaughlin
  - b. Training and Special Operations Report – Deputy Chief Low
6. Investigation Section Report – Deputy Chief Hanson
7. Disposition of Fixed Asset 18-003 – Crown Vic. & Hose – Director Bishop

**F. Awards and Recognition**

Chief Schuldt recognized the completion of probation for Fire Fighters Michael Tomaselli, Manuel Correa, and Matthew Donovan.

**MINUTES**  
**GREATER NAPLES FIRE RESCUE DISTRICT**  
**BOARD OF FIRE COMMISSIONERS MEETING**  
**January 9, 2018**

**G. Fire Chief's Report – Chief Schuldt**

Chairman Cross asked for the Chief to report on issues of importance and let the written report stand as reported. Chief Schuldt reported on the following:

- Congratulations to the newly elected Union Officers
- Wed. Jan. 17, 2018, Lt. Inspector John Bigica will receive the FFCA Fire Inspector of the Year award.
- The ISO summary inspection report has been received and reviewed. GNFD retained a 4/10 rating and has the opportunity to achieve a 3/10, through development and implementation of a program to improve in several areas; deployment, training, hydrants/flow tests and pre-fire planning. The improvement plan is due within 90 days and implementation over 12 months at which time a review would take place. Commissioner Gerrity asked what the change in rating would equate to the residents. Chief Schuldt stated there would be a saving, through the insurance company formula used to calculate a lower ISO rating.

**H. Chapter 175 Firefighters' Pension Plan – Chairman Arroyo**  
No Report

**I. Local 2396 Report – President Trenton Mading**

- New officers have been elected: President Trento Mading, VP Brandon Bunting, Secretary Greg Baker, Treasurer Chris Rossi, District President John Taylor, Executive Board Members Joey Brown and Tim Garner.
- Recently had Labor meeting to discuss Article 41, with the Chief Schuldt, Director Bishop and District Attorney, attorney is nice.
- The recent two Labor Management meeting have been a little more difficult without the Fire Chief is attendance, but we are still meeting.
- VP Bunting added we are setting up meetings, Chief Schuldt responded that we are committed.

**II. OLD BUSINESS**

**A. Emergency Services Task Force Meeting – Commissioner Hemping**

Next meeting is January 18, 2018.

**B. Greater Naples/North Collier Merger Update – Chief Schuldt**

Commissioner Hemping requested the agenda item name be changed to collaboration verses merger.

Chief provided an update; Executive staffs from both organizations continue to meet bi-weekly focused on the joint staffing of Station 24/47 and other areas of collaboration including training, fleet maintenance, and Fire and Life Safety. *Commissioner Hemping made a motion in support of the Chiefs expediting the operational joint staffing plan at Station 24/47 to begin realizing savings on personnel costs. Commissioner Gerrity Seconded the motion. Motion passed 8-0.*

**MINUTES**  
**GREATER NAPLES FIRE RESCUE DISTRICT**  
**BOARD OF FIRE COMMISSIONERS MEETING**  
**January 9, 2018**

**C. AIW –International Fellowship Program Agreement – Chief Schuldt**

The International Training Program Agreement between the International Association of Fire Chiefs (IAFC) and the Greater Naples Fire Rescue District was presented along with details of the program. Commissioner questions; Page- Do the extra people count towards ISO? Schuldt - we will ask. Gerrity- What level of training do they have? Schuldt - all certified Firefighters with different levels of experience between 5-15 years. They are additional people, the fourth person if you will, not a replacement. Cross- Are they covered by our insurance? Bishop - yes for vehicle insurance and driving, no for health insurance. Medical is covered by Aramco. Gerrity- Where do they live? Schuldt- they find local housing. Cross stated they have all been back ground checked. Gerrity- Do we have to supervise? Schuldt- yes and write evaluations. The District is in the process of putting together a team to lead discussions including employees from all ranks. Captain Weinbaum has shown interest. *Commissioner Stedman made the motion to approve the agreement, Commissioner Cottiers seconded the motion. Motion passed 8-0.*

**D. 2017-2018 Financial Strategy Update – Chief Schuldt**

A comprehensive list, including focusing on hurricane repairs with insurance funds, mitigation strategies with FEMA, normal repairs and maintenance, limited use of dedicate reserves, utilization of grants, reassessing current capital improvements, equipment needs, delayed hiring, delayed e-fleet ordering and travel/memberships, was provided to the Board as items identified which staff will focus on to help limit the use of reserve funds this budget year. Commissioner Page asked which positions were being delayed. Schuldt - an administrative assistant, training specialist, and warehouse technician. Commissioner Hemping asked about the fire truck purchases. Chief Schuldt reminded the Board the contact has been executed, we bought them. Commissioner Cross asked if other stations could be looked at for co-sharing. Schuldt mentioned Lord's Way is set to be a shared station with EMS. Commissioner Gerrity asked about Station 76 co-staffing with North Collier. Schuldt - North Collier is not in a position to move forward with that station. Gerrity- What about a Brown out when Overtime needed? Is the station prudent for firefighting as the truck doesn't have firefighting services? Schuldt- running 4-5 calls per day makes the short answer yes, but there is an intangible value of having a truck to cover other stations during training and on calls. Commissioner Cross, what is the time frame to negotiated? How do we attack the OT issue? Schuldt - the current contract is up in August, approximately 6 months. Commissioner Henning, the Chiefs presentation is on track to save, however the budget is very tight, we need to support the Chief and address the overtime issue. Commissioner Boyer added we need to test as many as you can so we can have alternates. Commissioner Stedman asked, what rank is causing the overtime? Chief Schuldt - Company Officers and Driver Engineers.

**MINUTES  
GREATER NAPLES FIRE RESCUE DISTRICT  
BOARD OF FIRE COMMISSIONERS MEETING  
January 9, 2018**

**III. NEW BUSINESS**

**A. AIW – 2018 AFG Application – Deputy Chief Low**

Chief Low presented the AFG application for the 2018-2019 budget cycle for the purpose of securing remote and/or portable training resources/props. Chief Schuldt the grant items give us a way to look at doing business differently. Commissioner Boyer, with a technology package you could save travel miles, fuel and out of service time. The training props may help with ISO. Commissioner Henning confirmed the request is just for permission to apply. Chief Low, Yes, once awarded the item would be brought back to the Board for discussion on the Match amount. *Commissioner Stedman moved to approve submitting for the 2018 AFG grant, Commissioner Hemping Seconded the motion, motion passed 8-0.*

**B. Public Comment on Items not listed on the Agenda**

**C. Comments by Commissioners**

**IV. ADJOURNMENT**

*Meeting adjourned 7:30pm.*

Duly passed with a vote of \_\_\_\_\_ to \_\_\_\_\_ and adopted in session on the 9th day of January.

\_\_\_\_\_  
**Chairman Brian Cross**

\_\_\_\_\_  
**Commissioner Rob Boyer**

\_\_\_\_\_  
**Commissioner Charles Cottiers**

\_\_\_\_\_  
**Commissioner Jeff Page**

\_\_\_\_\_  
**Commissioner Kevin Gerrity**

\_\_\_\_\_  
**Commissioner Steve Hemping**

\_\_\_\_\_  
**Commissioner Tom Henning**

\_\_\_\_\_  
**Commissioner David Stedman**

**Balance Sheet  
As of 1/31/2018**

**Greater Naples Fire Rescue District (GNF)**

<b>Assets</b>			
<b>CASH IN BANK</b>			
10100-001-0000-001	GENERAL FUND CASH ACCOUNT - GNFRD	\$	16,092,500.14
10100-001-0000-002	PAYROLL - GNFRD	\$	1,060,512.77
10100-001-0000-003	DENTAL ACCOUNT (GNFRD)	\$	35,775.25
10100-001-0000-004	HEALTH FUND (GNFRD)	\$	124,558.07
10100-001-0000-005	UHC - MEDICARE - GNFRD	\$	30,726.86
10100-001-0015-000	DEBT SERVICE RESERVE FUND	\$	700,880.01
10100-001-0200-000	FIRST FLORIDA INTEGRITY BANK	\$	2,064,771.38
	<b>Total CASH IN BANK:</b>		<b>\$ 20,109,724.48</b>
<b>ACCOUNTS RECEIVABLE</b>			
11500-001-0001-000	COLLIER COUNTY RECEIVABLE	\$	18,974.67
11500-001-0003-000	EMPLOYEE RECEIVABLE	\$	5,485.87
11500-001-0004-000	YEAR END ACCOUNTS RECEIVABLE	\$	189.61
11500-001-0007-000	MISCELLANEOUS RECEIVABLE	\$	39,912.81
11500-001-0008-000	MISC. RECEIVABLE- PREVENTION	\$	27,460.00
11500-001-0009-000	COLLIER COUNTY RECEIVABLE	\$	327.81
11500-001-0011-000	RETURNED CHECKS	\$	160.00
11500-001-0013-000	FALSE ALARM RECEIVABLE	\$	2,735.43
	<b>Total ACCOUNTS RECEIVABLE:</b>		<b>\$ 95,246.20</b>
<b>DUE FROM OTHER FUNDS</b>			
13100-001-0003-000	DUE FROM PUBLIC PROGRAMS TO GENERAL FUND	\$	348.21
13300-001-0000-001	DUE FROM M63	\$	25,963.37
	<b>Total DUE FROM OTHER FUNDS:</b>		<b>\$ 26,311.58</b>
<b>PROPERTY HELD FOR SALE</b>			
15000-001-0000-000	PROPERTY HELD FOR SALE	\$	1,000,000.00
	<b>Total PROPERTY HELD FOR SALE:</b>		<b>\$ 1,000,000.00</b>
<b>PREPAID</b>			
15500-001-0000-000	PREPAID EXPENSES	\$	6,356.68
15500-001-0001-000	PREPAID INSURANCE	\$	35,285.05
15500-001-0004-000	DEPOSIT IN ZENNITH FOR GRIT CLAIMS	\$	20,732.79
	<b>Total PREPAID:</b>		<b>\$ 62,374.52</b>
	<b>Total Assets:</b>		<b>\$ 21,293,656.78</b>
<b>Liabilities</b>			
<b>VOUCHER PAYABLE</b>			
20100-001-0000-001	VOUCHERS PAYABLE	\$	926.86
20100-001-0000-002	AFLAC - PRE TAX	\$	-14.91
20100-001-0000-009	EE ELECTIVE LIFE INS - STANDARD INS	\$	-83.60
20100-001-0000-010	EE CONTRIBUTION TO FRS	\$	-0.19
20100-001-0000-013	FSA CONTRIBUTION	\$	1,106.41
20100-001-0000-014	GARNISHMENT	\$	-25.00
20100-001-0000-017	Garnishment %	\$	-806.94
20100-001-0000-020	EMPLOYEES HELPING EMPLOYEES FUND	\$	120.00
	<b>Total VOUCHER PAYABLE:</b>		<b>\$ 1,222.63</b>
<b>DUE TO OTHER FUNDS</b>			
20700-001-0001-000	DUE TO IMPACT FEE FUND FROM GENERAL	\$	1,000,000.00
	<b>Total DUE TO OTHER FUNDS:</b>		<b>\$ 1,000,000.00</b>
<b>OTHER CURRENT LIABILITIES</b>			
22900-001-0001-000	GRIT BANKRUPTCY DISPURSEMENT	\$	33,853.64

**Balance Sheet  
As of 1/31/2018**

**Greater Naples Fire Rescue District (GNF)**

	<b>Total OTHER CURRENT LIABILITIES:</b>		\$ 33,853.64
	<b>Total Liabilities:</b>		\$ 1,035,076.27
<b>Equity</b>			
<b>PREPAID EXPENSES</b>			
27300-000-0000-001	PREPAID EXPENSES	\$ 292,348.85	
27300-000-0000-002	LAND HELD FOR SALE	\$ 1,000,000.00	
	<b>Total PREPAID EXPENSES:</b>		\$ 1,292,348.85
<b>FUND BALANCE</b>			
28100-001-0000-000	FUND BALANCE - RESTRICTED	\$ 697,321.00	
28300-001-0000-000	FUND BALANCE ASSIGNED	\$ 3,160,440.00	
28400-001-0000-000	FUND BALANCE - UNASSIGNED	\$ 4,288,284.63	
28400-001-0000-002	Retained Earnings-Current Year	\$ 12,781,206.79	
28400-001-0000-002	FUND BALANCE CURRENT YEAR	\$ -1,961,020.76	
	<b>Total FUND BALANCE:</b>		\$ 18,966,231.66
	<b>Total Equity:</b>		\$ 20,258,580.51
	<b>Total Liabilities &amp; Equity:</b>		<u>\$ 21,293,656.78</u>



**GNFRD INCOME STATEMENT**  
**For The 4 Periods Ended 1/31/2018**

**Greater Naples Fire Rescue District (GNF)**

		Period to Date	%	ORIGINAL PTD Budget	%	Year to Date	%	ORIGINAL Annual Budget	%
<b>Revenue</b>									
<b>TAXES</b>									
31100-001-0000-001	AD VALOREM	699,364.52	44.29	2,061,917.75	86.73	22,442,560.02	91.94	24,743,013.00	86.73
31100-001-0000-002	PRIOR YEAR TAXES	433.59	0.03	416.67	0.02	752.03	0.00	5,000.00	0.02
31100-001-0000-003	WARRANT DISTRIBUTIONS	116.08	0.01	1,054.17	0.04	327.10	0.00	12,650.00	0.04
31100-001-0000-004	COUNTY HELD DISTRIBUTIONS	50.31	0.00	52.08	0.00	100.88	0.00	625.00	0.00
31100-001-0000-005	AD VALOREM INTEREST	0.00	0.00	66.67	0.00	0.00	0.00	800.00	0.00
31100-001-0000-007	EXCESS FEES	0.00	0.00	5,833.33	0.25	0.00	0.00	70,000.00	0.25
31100-001-2060-012	AD VALOREM - OCHOPEE	402,782.73	25.50	120,028.42	5.05	629,880.23	2.58	1,440,341.00	5.05
31100-001-2060-013	OCHOPEE MANAGEMENT FEE	0.00	0.00	47,091.67	1.98	565,100.00	2.32	565,100.00	1.98
<b>Total TAXES:</b>		<b>1,102,747.23</b>	<b>69.83</b>	<b>2,236,460.76</b>	<b>94.07</b>	<b>23,638,720.26</b>	<b>96.84</b>	<b>26,837,529.00</b>	<b>94.07</b>
<b>INSPECTION FEES NEW</b>									
32901-001-0000-010	INSPECTION FEES NEW CONSTRUCT	50,411.45	3.19	40,791.67	1.72	148,953.60	0.61	489,500.00	1.72
32901-001-0000-011	INSP/RE-INSP FEES NEW CONST. - TII	900.00	0.06	333.33	0.01	2,775.00	0.01	4,000.00	0.01
32901-001-0000-012	RE-INSPECTOR - NEW	1,425.00	0.09	4,333.33	0.18	7,150.00	0.03	52,000.00	0.18
32901-001-0000-014	KEY BOX INSPECTION - NEW	0.00	0.00	550.00	0.02	0.00	0.00	6,600.00	0.02
32901-001-0000-015	HYDRANT THRUST BLOCK	250.00	0.02	750.00	0.03	1,050.00	0.00	9,000.00	0.03
32901-001-0000-016	HYDRANT THRUST BLOCK RE-INSP	0.00	0.00	83.33	0.00	0.00	0.00	1,000.00	0.00
32901-001-0000-017	FIRE FLOWS	1,500.00	0.09	2,000.00	0.08	7,650.00	0.03	24,000.00	0.08
32901-001-0000-018	FIRE FLOW RE-INSPECTION	0.00	0.00	150.00	0.01	450.00	0.00	1,800.00	0.01
32901-001-2060-000	INSPECTION FEES NEW - OCHOPEE	1,153.20	0.07	250.00	0.01	1,153.20	0.00	3,000.00	0.01
<b>Total INSPECTION FEES NEW:</b>		<b>55,639.65</b>	<b>3.52</b>	<b>49,241.66</b>	<b>2.07</b>	<b>169,181.80</b>	<b>0.69</b>	<b>590,900.00</b>	<b>2.07</b>
<b>INSPECTION FEES EXISTING</b>									
32910-001-1000-110	IINSP. FEES EXISTING - TIMED	0.00	0.00	12.50	0.00	150.00	0.00	150.00	0.00
32910-001-1000-111	OCCUPATIONAL INSPECTION	1,900.00	0.12	2,258.75	0.10	7,675.00	0.03	27,105.00	0.10
32910-001-1000-112	RE-INSPECTION FEES - EXISTING	50.00	0.00	250.00	0.01	200.00	0.00	3,000.00	0.01
32910-001-1000-113	INSPECTION FEES 0 - 3,000 SQ FT EXI	250.00	0.02	416.67	0.02	1,075.00	0.00	5,000.00	0.02
32910-001-1000-114	INSPECTION FEES 3,001 - 30,000 SQ F	300.00	0.02	250.00	0.01	1,100.00	0.00	3,000.00	0.01
32910-001-1000-115	INSPECTION FEES 30,001 - 100,000 SC	0.00	0.00	208.33	0.01	450.00	0.00	2,500.00	0.01
32910-001-1000-116	INSPECTION FEES OVER 100,000 SQ F	350.00	0.02	500.00	0.02	600.00	0.00	6,000.00	0.02
32910-001-1000-117	KEY BOX INSPECTIONS - EXISTING	450.00	0.03	20.83	0.00	1,425.00	0.01	250.00	0.00
<b>Total INSPECTION FEES EXISTING:</b>		<b>3,300.00</b>	<b>0.21</b>	<b>3,917.08</b>	<b>0.16</b>	<b>12,675.00</b>	<b>0.05</b>	<b>47,005.00</b>	<b>0.16</b>
<b>FIREFIGHTERS SUPPLEMENT INCOME</b>									
33500-001-0000-210	FIREFIGHTER SUPPLEMENTAL INCOM	0.00	0.00	5,080.00	0.21	15,200.00	0.06	60,960.00	0.21
<b>Total FIREFIGHTERS SUPPLEMENT INCOME:</b>		<b>0.00</b>	<b>0.00</b>	<b>5,080.00</b>	<b>0.21</b>	<b>15,200.00</b>	<b>0.06</b>	<b>60,960.00</b>	<b>0.21</b>

Run Date: 2/5/2018 5:55:25PM  
 G/L Date: 1/31/2018

**GNFRD INCOME STATEMENT**  
**For The 4 Periods Ended 1/31/2018**

**Greater Naples Fire Rescue District (GNF)**

		Period to Date	%	ORIGINAL PTD Budget	%	Year to Date	%	ORIGINAL Annual Budget	%
<b>FIRE &amp; LIFE SAFETY CHARGES &amp; FEES</b>									
34200-001-0000-202	REIMBURSEMENT FOR OT	600.00	0.04	916.67	0.04	1,800.00	0.01	11,000.00	0.04
34200-001-0000-203	FALSE ALARMS	3,950.00	0.25	2,083.33	0.09	11,950.00	0.05	25,000.00	0.09
34200-001-0000-204	FIRE WATCH	0.00	0.00	604.17	0.03	1,750.00	0.01	7,250.00	0.03
34200-001-0000-206	ISO LETTERS	50.00	0.00	25.00	0.00	150.00	0.00	300.00	0.00
34200-001-0000-207	KEY BOXES SOLD	380.00	0.02	20.83	0.00	1,345.00	0.01	250.00	0.00
34200-001-0000-208	DUPLICATE NOC'S	100.00	0.01	83.33	0.00	210.00	0.00	1,000.00	0.00
34200-001-0000-209	DEFICIENCY REVIEWS	100.00	0.01	250.00	0.01	900.00	0.00	3,000.00	0.01
34200-001-0000-210	VARIANCE REQUESTS	0.00	0.00	208.33	0.01	1,000.00	0.00	2,500.00	0.01
34200-001-0000-211	FIRE WORK PERMITS	0.00	0.00	125.00	0.01	300.00	0.00	1,500.00	0.01
34200-001-0000-212	TRAINING DONE BY F & L SAFETY	0.00	0.00	50.00	0.00	80.00	0.00	600.00	0.00
34200-001-0000-904	SPECIAL EVENT INSPECTION FEES	0.00	0.00	41.67	0.00	0.00	0.00	500.00	0.00
34200-001-0000-905	OTHER F & L MISC. INCOME	200.00	0.01	41.67	0.00	1,119.65	0.00	500.00	0.00
<b>Total FIRE &amp; LIFE SAFETY CHARGES &amp; FEES:</b>		<b>5,380.00</b>	<b>0.34</b>	<b>4,450.00</b>	<b>0.19</b>	<b>20,604.65</b>	<b>0.08</b>	<b>53,400.00</b>	<b>0.19</b>
<b>INTEREST EARNINGS</b>									
36100-001-0000-001	INTEREST EARNINGS	7,570.58	0.48	2,500.00	0.11	17,140.10	0.07	30,000.00	0.11
<b>Total INTEREST EARNINGS:</b>		<b>7,570.58</b>	<b>0.48</b>	<b>2,500.00</b>	<b>0.11</b>	<b>17,140.10</b>	<b>0.07</b>	<b>30,000.00</b>	<b>0.11</b>
<b>RENTALS &amp; LEASES</b>									
36200-001-0000-001	ADMIN RENTAL PROPERTY	0.00	0.00	200.00	0.01	800.00	0.00	2,400.00	0.01
36200-001-0000-002	CELL TOWER LEASE CONTRACT	3,265.81	0.21	10,833.33	0.46	12,877.21	0.05	130,000.00	0.46
36200-001-0000-003	PUBLIC SAFETY - STATION 21	592.45	0.04	470.00	0.02	3,980.83	0.02	5,640.00	0.02
36200-001-0000-004	PUBLIC SAFETY - STATION 22	327.81	0.02	408.33	0.02	2,282.92	0.01	4,900.00	0.02
36200-001-0000-005	PUBLIC SAAFETY - STATION 23	300.00	0.02	300.00	0.01	1,200.00	0.00	3,600.00	0.01
36200-001-0000-006	PUBLIC SAFETY - STATION 20	761.61	0.05	470.00	0.02	3,686.83	0.02	5,640.00	0.02
<b>Total RENTALS &amp; LEASES:</b>		<b>5,247.68</b>	<b>0.33</b>	<b>12,681.66</b>	<b>0.53</b>	<b>24,827.79</b>	<b>0.10</b>	<b>152,180.00</b>	<b>0.53</b>
<b>DISPOSITION OF FIXED ASSETS</b>									
36400-001-0000-001	DISPOSITION OF FIXED ASSETS	0.00	0.00	1,250.00	0.05	0.00	0.00	15,000.00	0.05
<b>Total DISPOSITION OF FIXED ASSETS:</b>		<b>0.00</b>	<b>0.00</b>	<b>1,250.00</b>	<b>0.05</b>	<b>0.00</b>	<b>0.00</b>	<b>15,000.00</b>	<b>0.05</b>
<b>CONTRIBUTIONS AND DONATIONS</b>									
36600-001-0000-001	CONTRIBUTIONS AND DONATIONS	75.00	0.00	125.00	0.01	2,575.00	0.01	1,500.00	0.01
<b>Total CONTRIBUTIONS AND DONATIONS:</b>		<b>75.00</b>	<b>0.00</b>	<b>125.00</b>	<b>0.01</b>	<b>2,575.00</b>	<b>0.01</b>	<b>1,500.00</b>	<b>0.01</b>
<b>OTHER MISCELLANEOUS INCOME</b>									
36900-001-0000-901	BLS TRAINING	0.00	0.00	41.67	0.00	0.00	0.00	500.00	0.00
36900-001-0000-902	FIRE MARSHALL MOU REIMBURSEME	12,732.20	0.81	3,750.00	0.16	25,464.40	0.10	45,000.00	0.16

Run Date: 2/5/2018 5:55:25PM

G/L Date: 1/31/2018

Page: 2

**GNFRD INCOME STATEMENT**  
**For The 4 Periods Ended 1/31/2018**

**Greater Naples Fire Rescue District (GNF)**

		Period to Date	%	ORIGINAL PTD Budget	%	Year to Date	%	ORIGINAL Annual Budget	%	
<b>OTHER MISCELLANEOUS INCOME</b>		(Continued)								
36900-001-0000-904	SHOP REVENUE	5,149.15	0.33	7,979.17	0.34	42,640.89	0.17	95,750.00	0.34	
36900-001-0000-906	OTHER MISC. INCOME	133.74	0.01	0.00	0.00	2,303.23	0.01	0.00	0.00	
36900-001-0500-046	HURRICANE IRMA REIM FOR DAMAGE	363,697.32	23.03	0.00	0.00	408,780.32	1.67	0.00	0.00	
36900-001-2060-901	MM63 EMPLOYEE COST REIMBURSEM	0.00	0.00	50,000.00	2.10	0.00	0.00	600,000.00	2.10	
36900-001-4010-046	VEHICLE REPAIR INSURANCE REIM.	17,562.07	1.11	0.00	0.00	29,016.62	0.12	0.00	0.00	
<b>Total OTHER MISCELLANEOUS INCOME:</b>		<b>399,274.48</b>	<b>25.28</b>	<b>61,770.84</b>	<b>2.60</b>	<b>508,205.46</b>	<b>2.08</b>	<b>741,250.00</b>	<b>2.60</b>	
<b>Total Revenue:</b>		<b>1,579,234.62</b>	<b>100.00</b>	<b>2,377,477.00</b>	<b>100.00</b>	<b>24,409,130.06</b>	<b>100.00</b>	<b>28,529,724.00</b>	<b>100.00</b>	
<b>Gross Profit:</b>		<b>1,579,234.62</b>	<b>100.00</b>	<b>2,377,477.00</b>	<b>100.00</b>	<b>24,409,130.06</b>	<b>100.00</b>	<b>28,529,724.00</b>	<b>100.00</b>	
<b>Expenses</b>										
<b>LEGISLATIVE SALARIES</b>										
51100-001-0000-011	LEGISLATIVE SALARIES (COMMISSIOI	0.00	0.00	4,000.00	0.17	13,716.53	0.06	48,000.00	0.17	
<b>Total LEGISLATIVE SALARIES:</b>		<b>0.00</b>	<b>0.00</b>	<b>4,000.00</b>	<b>0.17</b>	<b>13,716.53</b>	<b>0.06</b>	<b>48,000.00</b>	<b>0.17</b>	
<b>EXECUTIVE SALARIES &amp; WAGES</b>										
51200-001-0000-011	EXECUTIVE SALARIES	59,031.08	3.74	118,363.92	4.98	540,705.94	2.22	1,420,367.00	4.98	
51200-001-0000-012	EXECUTIVE 175 PENSION CONTRACT	195.48	0.01	395.83	0.02	1,705.10	0.01	4,750.00	0.02	
<b>Total EXECUTIVE SALARIES &amp; WAGES:</b>		<b>59,226.56</b>	<b>3.75</b>	<b>118,759.75</b>	<b>5.00</b>	<b>542,411.04</b>	<b>2.22</b>	<b>1,425,117.00</b>	<b>5.00</b>	
<b>ADMINISTRATIVE SALARIES</b>										
51300-001-1000-012	SALARIES - NON BARGAINING (ADMIN	37,025.60	2.34	89,358.42	3.76	278,661.32	1.14	1,072,301.00	3.76	
51300-001-1000-014	OVERTIME (NON-BARGAINING)	2,934.37	0.19	6,462.50	0.27	18,640.35	0.08	77,550.00	0.27	
<b>Total ADMINISTRATIVE SALARIES:</b>		<b>39,959.97</b>	<b>2.53</b>	<b>95,820.92</b>	<b>4.03</b>	<b>297,301.67</b>	<b>1.22</b>	<b>1,149,851.00</b>	<b>4.03</b>	
<b>BARGAINING UNIT SHIFT SALARIES &amp; WAGES</b>										
51310-001-2000-012	BARGAINING UNIT SALARIES - SHIFT	416,449.18	26.37	891,870.83	37.51	4,241,336.99	17.38	10,702,450.00	37.51	
51310-001-2000-013	FIREFIGHTERS - PART TIME	336.00	0.02	13,104.00	0.55	8,046.43	0.03	157,248.00	0.55	
51310-001-2000-014	OVERTIME - SHIFT	3,010.95	0.19	112,724.33	4.74	658,914.91	2.70	1,352,692.00	4.74	
<b>Total BARGAINING UNIT SHIFT SALARIES &amp; WAGES:</b>		<b>419,796.13</b>	<b>26.58</b>	<b>1,017,699.16</b>	<b>42.81</b>	<b>4,908,298.33</b>	<b>20.11</b>	<b>12,212,390.00</b>	<b>42.81</b>	
<b>BARGAINING UNIT - NON SHIFT</b>										
51320-001-3000-013	FIRE & LIFE SAFETY WAGES	30,252.80	1.92	60,993.25	2.57	220,276.47	0.90	731,919.00	2.57	
51320-001-3000-014	OVERTIME FIRE & LIFE SAFETY	774.25	0.05	10,416.67	0.44	18,681.59	0.08	125,000.00	0.44	
<b>Total BARGAINING UNIT - NON SHIFT:</b>		<b>31,027.05</b>	<b>1.96</b>	<b>71,409.92</b>	<b>3.00</b>	<b>238,958.06</b>	<b>0.98</b>	<b>856,919.00</b>	<b>3.00</b>	
<b>EARNINGS OTHER</b>										
51330-001-9000-011	DISPLACEMENT PAY	0.00	0.00	12.50	0.00	0.00	0.00	150.00	0.00	

Run Date: 2/5/2018 5:55:25PM  
 G/L Date: 1/31/2018

**GNFRD INCOME STATEMENT**  
**For The 4 Periods Ended 1/31/2018**

**Greater Naples Fire Rescue District (GNF)**

		Period to Date	%	ORIGINAL PTD Budget	%	Year to Date	%	ORIGINAL Annual Budget	%	
<b>EARNINGS OTHER</b>		(Continued)								
51330-001-9000-013	HOLIDAY	450.00	0.03	18,772.33	0.79	5,110.00	0.02	225,268.00	0.79	
51330-001-9000-014	VACATION	0.00	0.00	10,000.00	0.42	13,753.23	0.06	120,000.00	0.42	
51330-001-9000-015	SICK TIME	0.00	0.00	21,363.92	0.90	8,891.25	0.04	256,367.00	0.90	
51330-001-9000-016	457 CONTRACTUAL	192.31	0.01	408.33	0.02	1,456.06	0.01	4,900.00	0.02	
51330-001-9010-011	LIFE INSURANCE OVER \$50,000	0.00	0.00	0.00	0.00	5,061.56	0.02	0.00	0.00	
51330-001-9010-012	LIFE INSURANCE OVER \$50,000	0.00	0.00	0.00	0.00	-5,061.56	-0.02	0.00	0.00	
51330-001-9011-012	CLOTHING ALLOWANCE	0.00	0.00	100.00	0.00	0.00	0.00	1,200.00	0.00	
51330-001-9012-011	DISABILITY BENEFITS	0.00	0.00	0.00	0.00	41,535.61	0.17	0.00	0.00	
51330-001-9012-012	NET DISABILITY BENEFITS	0.00	0.00	0.00	0.00	-41,535.61	-0.17	0.00	0.00	
<b>Total EARNINGS OTHER:</b>		<b>642.31</b>	<b>0.04</b>	<b>50,657.08</b>	<b>2.13</b>	<b>29,210.54</b>	<b>0.12</b>	<b>607,885.00</b>	<b>2.13</b>	
<b>DEBT SERVICE</b>										
51700-001-0000-071	DEBT SERVICE - PRINCIPAL PAYMENT	349.88	0.02	23,122.00	0.97	93,191.53	0.38	277,464.00	0.97	
51700-001-0000-072	DEBT SERVICE - INTEREST PAYMENT	0.00	0.00	6,333.33	0.27	25,350.68	0.10	76,000.00	0.27	
<b>Total DEBT SERVICE:</b>		<b>349.88</b>	<b>0.02</b>	<b>29,455.33</b>	<b>1.24</b>	<b>118,542.21</b>	<b>0.49</b>	<b>353,464.00</b>	<b>1.24</b>	
<b>FICA TAXES</b>										
52201-001-0000-011	FICA TAXES	86,750.97	5.49	103,873.67	4.37	447,328.14	1.83	1,246,484.00	4.37	
<b>Total FICA TAXES:</b>		<b>86,750.97</b>	<b>5.49</b>	<b>103,873.67</b>	<b>4.37</b>	<b>447,328.14</b>	<b>1.83</b>	<b>1,246,484.00</b>	<b>4.37</b>	
<b>RETIREMENT CONTRIBUTIONS</b>										
52202-001-0010-022	FRS CONTRIBUTIONS	201,898.71	12.78	187,815.83	7.90	809,423.24	3.32	2,253,790.00	7.90	
52202-001-0011-022	175 RETIREMENT PLAN CONTRIBUTION	45,456.52	2.88	48,770.75	2.05	172,961.60	0.71	585,249.00	2.05	
52202-001-0012-022	NATIONWIDE RETIREMENT PLAN	3,830.04	0.24	5,000.00	0.21	13,779.08	0.06	60,000.00	0.21	
52202-001-0013-022	DISTRICT DEF COMP MATCH	1,750.00	0.11	863.75	0.04	6,450.00	0.03	10,365.00	0.04	
<b>Total RETIREMENT CONTRIBUTIONS:</b>		<b>252,935.27</b>	<b>16.02</b>	<b>242,450.33</b>	<b>10.20</b>	<b>1,002,613.92</b>	<b>4.11</b>	<b>2,909,404.00</b>	<b>10.20</b>	
<b>LIFE AND HEALTH INSURANCE</b>										
52205-001-0010-023	INS BENEFITS FIXED - DENTAL	1,361.91	0.09	1,417.00	0.06	5,479.44	0.02	17,004.00	0.06	
52205-001-0011-023	INSURANCE BENEFITS FIXED - LIFE IN	3,646.60	0.23	3,597.00	0.15	18,125.84	0.07	43,164.00	0.15	
52205-001-0012-023	INS BENEFITS FIXED - MEDICAL	235,762.09	14.93	237,177.42	9.98	1,276,718.33	5.23	2,846,129.00	9.98	
52205-001-0013-023	INS BENEFITS FIXED - STD/LTD	8,111.48	0.51	8,183.50	0.34	40,260.31	0.16	98,202.00	0.34	
52205-001-0014-023	INS BENEFITS FIXED - VISION	2,310.50	0.15	2,680.00	0.11	11,528.83	0.05	32,160.00	0.11	
52205-001-0015-023	INS BENEFITS - DENTAL CLAIMS	12,828.94	0.81	11,916.67	0.50	41,338.63	0.17	143,000.00	0.50	
52205-001-0016-023	INS BENEFITS - MEDICAL HRA	56,804.90	3.60	47,666.67	2.00	261,264.49	1.07	572,000.00	2.00	
<b>Total LIFE AND HEALTH INSURANCE:</b>		<b>320,826.42</b>	<b>20.32</b>	<b>312,638.26</b>	<b>13.15</b>	<b>1,654,715.87</b>	<b>6.78</b>	<b>3,751,659.00</b>	<b>13.15</b>	
<b>WORKERS COMPENSATION</b>										

**GNFRD INCOME STATEMENT**  
**For The 4 Periods Ended 1/31/2018**

**Greater Naples Fire Rescue District (GNF)**

		Period to Date	%	ORIGINAL PTD Budget	%	Year to Date	%	ORIGINAL Annual Budget	%
<b>WORKERS COMPENSATION</b> (Continued)									
52210-001-0010-024	WORKERS COMPENSATION PREMIUM	33,753.65	2.14	33,299.92	1.40	372,570.60	1.53	399,599.00	1.40
52210-001-0012-024	EXPENSES FOR GRIT CLAIMANTS	0.00	0.00	208.33	0.01	601.69	0.00	2,500.00	0.01
<b>Total WORKERS COMPENSATION:</b>		<b>33,753.65</b>	<b>2.14</b>	<b>33,508.25</b>	<b>1.41</b>	<b>373,172.29</b>	<b>1.53</b>	<b>402,099.00</b>	<b>1.41</b>
<b>UNEMPLOYMENT COMPENSATION</b>									
52215-001-0000-025	RE-EMPLOYMENT TAX	0.00	0.00	5,183.17	0.22	0.00	0.00	62,198.00	0.22
52215-001-0000-026	POST EMPLOYMENT BENEFITS (PEHF)	10,000.00	0.63	13,750.00	0.58	170,000.00	0.70	165,000.00	0.58
<b>Total UNEMPLOYMENT COMPENSATION:</b>		<b>10,000.00</b>	<b>0.63</b>	<b>18,933.17</b>	<b>0.80</b>	<b>170,000.00</b>	<b>0.70</b>	<b>227,198.00</b>	<b>0.80</b>
<b>PROFESSIONAL SERVICES</b>									
52220-001-0000-031	PROFESSIONAL SERVICES	3,142.84	0.20	23,045.83	0.97	23,795.86	0.10	276,550.00	0.97
52220-001-0011-031	CONTRACTUAL SERVICES - ADV COLI	16,500.70	1.04	37,500.00	1.58	452,233.21	1.85	450,000.00	1.58
52220-001-0012-031	CONTRACTUAL SERVICES - IMPACT F	753.60	0.05	1,000.00	0.04	3,352.15	0.01	12,000.00	0.04
52220-001-0013-031	CONTRACTUAL SERVICES - PROPER	50,074.72	3.17	10,530.00	0.44	76,147.46	0.31	126,360.00	0.44
52220-001-1000-031	CONTRACTUAL SERVICES - GENERAL	17,981.16	1.14	30,043.17	1.26	105,605.51	0.43	360,518.00	1.26
52220-001-2060-031	CONTRACTUAL SERVICES - OCHOPEI	9,270.90	0.59	1,633.75	0.07	10,972.70	0.04	19,605.00	0.07
52220-001-3000-031	CONTRACTUAL SERV FIRE & LIFE SAF	2,816.25	0.18	0.00	0.00	4,830.58	0.02	0.00	0.00
52220-001-4000-031	CONTRACTUAL SERVICES SHOP	0.00	0.00	2,250.00	0.09	0.00	0.00	27,000.00	0.09
<b>Total PROFESSIONAL SERVICES:</b>		<b>100,540.17</b>	<b>6.37</b>	<b>106,002.75</b>	<b>4.46</b>	<b>676,937.47</b>	<b>2.77</b>	<b>1,272,033.00</b>	<b>4.46</b>
<b>ACCOUNTING &amp; AUDITING</b>									
52225-001-0000-032	ACCOUNTING & AUDITING	500.00	0.03	2,308.33	0.10	1,500.00	0.01	27,700.00	0.10
<b>Total ACCOUNTING &amp; AUDITING:</b>		<b>500.00</b>	<b>0.03</b>	<b>2,308.33</b>	<b>0.10</b>	<b>1,500.00</b>	<b>0.01</b>	<b>27,700.00</b>	<b>0.10</b>
<b>CURRENT CHARGES</b>									
52230-001-0000-037	CURRENT CHARGES	453.70	0.03	3,690.00	0.16	4,526.92	0.02	44,280.00	0.16
<b>Total CURRENT CHARGES:</b>		<b>453.70</b>	<b>0.03</b>	<b>3,690.00</b>	<b>0.16</b>	<b>4,526.92</b>	<b>0.02</b>	<b>44,280.00</b>	<b>0.16</b>
<b>TRAVEL &amp; PER DIEM</b>									
52235-001-0010-040	EMPLOYEE TOLLS REIMBURSEMENT	0.00	0.00	12.50	0.00	0.00	0.00	150.00	0.00
<b>Total TRAVEL &amp; PER DIEM:</b>		<b>0.00</b>	<b>0.00</b>	<b>12.50</b>	<b>0.00</b>	<b>0.00</b>	<b>0.00</b>	<b>150.00</b>	<b>0.00</b>
<b>COMMUNICATIONS &amp; FREIGHT</b>									
52240-001-0000-041	COMMUNICATIONS- CELL PHONES	3,604.02	0.23	3,250.00	0.14	6,800.97	0.03	39,000.00	0.14
52240-001-0000-042	FREIGHT & POSTAGE SERVICES	142.23	0.01	291.67	0.01	1,225.03	0.01	3,500.00	0.01
52240-001-0015-041	COMMUNICATIONS-GENERAL	12,327.17	0.78	10,541.67	0.44	38,621.06	0.16	126,500.00	0.44
52240-001-2060-041	COMMUNICATIONS - OCHOPEE	2,302.59	0.15	1,666.67	0.07	8,200.94	0.03	20,000.00	0.07
<b>Total COMMUNICATIONS &amp; FREIGHT:</b>		<b>18,376.01</b>	<b>1.16</b>	<b>15,750.01</b>	<b>0.66</b>	<b>54,848.00</b>	<b>0.22</b>	<b>189,000.00</b>	<b>0.66</b>

Run Date: 2/5/2018 5:55:25PM  
 G/L Date: 1/31/2018

**GNFRD INCOME STATEMENT**  
**For The 4 Periods Ended 1/31/2018**

**Greater Naples Fire Rescue District (GNF)**

		Period to Date	%	ORIGINAL PTD Budget	%	Year to Date	%	ORIGINAL Annual Budget	%
<b>UTILITY SERVICES</b>									
52245-001-0000-043	UTILITIES	15,239.98	0.97	13,875.83	0.58	60,857.56	0.25	166,510.00	0.58
52245-001-2060-043	UTILITY SERVICES - OCHOPEE	727.90	0.05	1,062.50	0.04	3,258.74	0.01	12,750.00	0.04
<b>Total UTILITY SERVICES:</b>		<b>15,967.88</b>	<b>1.01</b>	<b>14,938.33</b>	<b>0.63</b>	<b>64,116.30</b>	<b>0.26</b>	<b>179,260.00</b>	<b>0.63</b>
<b>RENTALS &amp; LEASES</b>									
52250-001-0000-044	RENTALS & LEASES	293.59	0.02	583.33	0.02	5,747.66	0.02	7,000.00	0.02
52250-001-0100-044	RENTALS & LEASES - FACILITIES	2,600.00	0.16	2,500.00	0.11	7,800.00	0.03	30,000.00	0.11
52250-001-3000-044	RENTALS & LEASES E-FLEET	5,180.73	0.33	5,180.75	0.22	20,726.18	0.08	62,169.00	0.22
<b>Total RENTALS &amp; LEASES:</b>		<b>8,074.32</b>	<b>0.51</b>	<b>8,264.08</b>	<b>0.35</b>	<b>34,273.84</b>	<b>0.14</b>	<b>99,169.00</b>	<b>0.35</b>
<b>INSURANCE GENERAL</b>									
52255-001-0000-045	GENERAL INSURANCE	119,364.93	7.56	30,425.50	1.28	121,251.93	0.50	365,106.00	1.28
<b>Total INSURANCE GENERAL:</b>		<b>119,364.93</b>	<b>7.56</b>	<b>30,425.50</b>	<b>1.28</b>	<b>121,251.93</b>	<b>0.50</b>	<b>365,106.00</b>	<b>1.28</b>
<b>REPAIR &amp; MAINT</b>									
52260-001-0000-046	REPAIR & MAINTENANCE - RADIO	751.70	0.05	916.67	0.04	3,691.70	0.02	11,000.00	0.04
52260-001-0500-046	REPAIRS CONCERNING HURRICANE I	27,878.94	1.77	0.00	0.00	27,878.94	0.11	0.00	0.00
52260-001-1000-046	REPAIR & MAINTENANCE - ADMIN	0.00	0.00	2,500.00	0.11	59.36	0.00	30,000.00	0.11
52260-001-1050-046	REPAIR & MAINTENANCE - FACILITIES	101.09	0.01	8,566.67	0.36	101.09	0.00	102,800.00	0.36
52260-001-2000-046	REPAIR & MAINTENANCE - OPERATIO	10,164.14	0.64	958.33	0.04	61,824.11	0.25	11,500.00	0.04
52260-001-2060-046	REPAIR AND MAINTENANCE - OCHOP	771.03	0.05	1,166.67	0.05	7,197.11	0.03	14,000.00	0.05
52260-001-3000-046	REPAIR & MAINT. FIRE & LIFE SAFETY	0.00	0.00	833.33	0.04	31.00	0.00	10,000.00	0.04
52260-001-4010-046	VEHICLE REPAIR - GNFRD VEHICLES	47,312.46	3.00	25,000.00	1.05	153,813.56	0.63	300,000.00	1.05
52260-001-4011-046	VEHICLE REPAIR - NON GNFRD	1,002.88	0.06	2,500.00	0.11	22,966.70	0.09	30,000.00	0.11
52260-001-4012-046	REPAIR & MAINTENANCE - MARINE VE	0.00	0.00	625.00	0.03	2,880.50	0.01	7,500.00	0.03
52260-001-4060-046	VEHICLE REPAIR - OCHOPEE	4,432.07	0.28	2,500.00	0.11	10,650.18	0.04	30,000.00	0.11
52260-001-4061-046	REPAIR & MAIN-OCHOPEE- MARINE V	0.00	0.00	500.00	0.02	0.00	0.00	6,000.00	0.02
52260-001-6010-046	REPAIR & MAINTENANCE - DIVE EQUI	0.00	0.00	1,408.33	0.06	0.00	0.00	16,900.00	0.06
52260-001-6012-046	REPAIR & MAINTENANCE - SCBA	0.00	0.00	833.33	0.04	323.50	0.00	10,000.00	0.04
52260-001-7000-046	REPAIR & MAINTENANCE - MEDICAL	0.00	0.00	375.00	0.02	35.00	0.00	4,500.00	0.02
<b>Total REPAIR &amp; MAINT:</b>		<b>92,414.31</b>	<b>5.85</b>	<b>48,683.33</b>	<b>2.05</b>	<b>291,452.75</b>	<b>1.19</b>	<b>584,200.00</b>	<b>2.05</b>
<b>PRINTING</b>									
52265-001-0000-047	PRINTING & BINDING	0.00	0.00	166.67	0.01	0.00	0.00	2,000.00	0.01
<b>Total PRINTING:</b>		<b>0.00</b>	<b>0.00</b>	<b>166.67</b>	<b>0.01</b>	<b>0.00</b>	<b>0.00</b>	<b>2,000.00</b>	<b>0.01</b>
<b>OFFICE SUPPLIES</b>									
52270-001-0000-051	OFFICE SUPPLIES	503.61	0.03	958.33	0.04	3,605.44	0.01	11,500.00	0.04

**GNFRD INCOME STATEMENT**  
**For The 4 Periods Ended 1/31/2018**

**Greater Naples Fire Rescue District (GNF)**

		Period to Date	%	ORIGINAL PTD Budget	%	Year to Date	%	ORIGINAL Annual Budget	%
<b>Total OFFICE SUPPLIES:</b>		503.61	0.03	958.33	0.04	3,605.44	0.01	11,500.00	0.04
<b>FUELS &amp; LUBRICANTS</b>									
52275-001-0010-052	FUELS & LUBRICANTS	1,036.61	0.07	958.33	0.04	8,904.81	0.04	11,500.00	0.04
52275-001-0011-052	FUELS & LUBRICANTS - UNLEADED	3,656.81	0.23	4,416.67	0.19	14,664.62	0.06	53,000.00	0.19
52275-001-0012-052	FUELS & LUBRICANTS - DIESEL	12,327.90	0.78	9,583.33	0.40	50,134.81	0.21	115,000.00	0.40
52275-001-0060-052	FUEL - OCHOPEE	0.00	0.00	708.33	0.03	0.00	0.00	8,500.00	0.03
52275-001-0090-052	MARINE NON-ETHANOL UNLEADED	2,965.82	0.19	708.33	0.03	5,439.17	0.02	8,500.00	0.03
<b>Total FUELS &amp; LUBRICANTS:</b>		19,987.14	1.27	16,374.99	0.69	79,143.41	0.32	196,500.00	0.69
<b>OPERATING SUPPLIES</b>									
52285-001-1000-052	OPERATING SUPPLIES - ADMIN	272.78	0.02	250.00	0.01	272.78	0.00	3,000.00	0.01
52285-001-2000-052	OPERATING SUPPLIES - OPS	1,671.86	0.11	2,916.67	0.12	14,243.36	0.06	35,000.00	0.12
52285-001-2060-052	OPERATING SUPPLIES - OCHOPEE	145.81	0.01	291.67	0.01	1,527.35	0.01	3,500.00	0.01
52285-001-3000-052	OPERATING SUPPLIES - FIRE & LIFE S	0.00	0.00	1,250.00	0.05	0.00	0.00	15,000.00	0.05
52285-001-4000-052	OPERATING SUPPLIES - FLEET	193.34	0.01	833.33	0.04	1,739.83	0.01	10,000.00	0.04
52285-001-5000-052	OPERATING SUPPLIES - TRAINING	24.99	0.00	416.67	0.02	24.99	0.00	5,000.00	0.02
52285-001-6000-052	OPERATING SUPPLIES - SPECIAL OPS	0.00	0.00	458.33	0.02	0.00	0.00	5,500.00	0.02
52285-001-7000-052	OPERATING SUPPLIES - MEDICAL	20.00	0.00	4,166.67	0.18	4,288.70	0.02	50,000.00	0.18
52285-001-8000-052	OPERATING SUPPLIES - FACILITIES/M	0.00	0.00	458.33	0.02	0.00	0.00	5,500.00	0.02
<b>Total OPERATING SUPPLIES:</b>		2,328.78	0.15	11,041.67	0.46	22,097.01	0.09	132,500.00	0.46
<b>EXTRAORDINARY ITEMS</b>									
52900-001-0000-099	EXTRAORDINARY ITEMS	0.00	0.00	0.00	0.00	130,368.39	0.53	0.00	0.00
<b>Total EXTRAORDINARY ITEMS:</b>		0.00	0.00	0.00	0.00	130,368.39	0.53	0.00	0.00
<b>SMALL EQUIPMENT</b>									
52910-001-0014-052	SMALL EQUIPMENT - LOGISTICS	0.00	0.00	125.00	0.01	0.00	0.00	1,500.00	0.01
52910-001-1000-049	SMALL EQUIPMENT - ADMIN	0.00	0.00	1,300.00	0.05	207.38	0.00	15,600.00	0.05
52910-001-2000-049	SMALL EQUIPMENT - OPS	2,073.15	0.13	6,947.58	0.29	20,178.71	0.08	83,371.00	0.29
52910-001-2060-049	SMALL EQUIPMENT - OCHOPEE	0.00	0.00	1,000.00	0.04	2,563.77	0.01	12,000.00	0.04
52910-001-3000-049	SMALL EQUIP - FIRE & LIFE SAFETY	0.00	0.00	1,704.67	0.07	0.00	0.00	20,456.00	0.07
52910-001-4000-049	SMALL EQUIPMENT - FLEET	139.00	0.01	250.00	0.01	2,191.82	0.01	3,000.00	0.01
52910-001-5000-049	SMALL EQUIP - TRAINING	1,283.86	0.08	625.00	0.03	1,283.86	0.01	7,500.00	0.03
52910-001-6010-049	SMALL EQUIP - DIVE RESCUE	0.00	0.00	833.33	0.04	5,112.50	0.02	10,000.00	0.04
52910-001-6011-049	SMALL EQUIP - HAZ MAT	0.00	0.00	166.67	0.01	0.00	0.00	2,000.00	0.01
52910-001-6012-049	SMALL EQUIP - USAR	0.00	0.00	416.67	0.02	0.00	0.00	5,000.00	0.02
52910-001-7000-049	SMALL EQUIP - MEDICAL	0.00	0.00	416.67	0.02	0.00	0.00	5,000.00	0.02
<b>Total SMALL EQUIPMENT:</b>		3,496.01	0.22	13,785.59	0.58	31,538.04	0.13	165,427.00	0.58

Run Date: 2/5/2018 5:55:25PM  
 G/L Date: 1/31/2018

**GNFRD INCOME STATEMENT**  
**For The 4 Periods Ended 1/31/2018**

**Greater Naples Fire Rescue District (GNF)**

		Period to Date	%	ORIGINAL PTD Budget	%	Year to Date	%	ORIGINAL Annual Budget	%
<b>UNIFORMS</b>									
52920-001-1000-052	UNIFORMS - ADMIN	0.00	0.00	916.67	0.04	799.14	0.00	11,000.00	0.04
52920-001-2010-052	UNIFORMS - OPERATIONS	585.34	0.04	7,083.33	0.30	1,370.23	0.01	85,000.00	0.30
52920-001-2011-052	UNIFORMS - BUNKER GEAR	0.00	0.00	9,475.00	0.40	0.00	0.00	113,700.00	0.40
52920-001-3000-052	UNIFORMS - FIRE & LIFE SAFETY	0.00	0.00	416.67	0.02	326.49	0.00	5,000.00	0.02
52920-001-6000-052	UNIFORMS - SPECIAL OPS	0.00	0.00	208.33	0.01	0.00	0.00	2,500.00	0.01
<b>Total UNIFORMS:</b>		<b>585.34</b>	<b>0.04</b>	<b>18,100.00</b>	<b>0.76</b>	<b>2,495.86</b>	<b>0.01</b>	<b>217,200.00</b>	<b>0.76</b>
<b>BOOKS, DUES</b>									
52930-001-1000-055	BOOKS, DUES - ADMIN	2,252.60	0.14	3,737.50	0.16	14,942.27	0.06	44,850.00	0.16
52930-001-2000-055	BOOKS, DUES - OPERATIONS	14,206.03	0.90	10,833.33	0.46	40,961.05	0.17	130,000.00	0.46
52930-001-3000-055	BOOKS, DUES - FIRE & LIFE SAFETY	4,410.39	0.28	1,363.75	0.06	8,738.27	0.04	16,365.00	0.06
52930-001-4000-055	BOOKS, DUES - FLEET	0.00	0.00	1,088.33	0.05	60.00	0.00	13,060.00	0.05
52930-001-5000-055	BOOKS, DUES - TRAINING	315.00	0.02	1,916.67	0.08	985.19	0.00	23,000.00	0.08
52930-001-5010-055	BOOKS, DUES - CPR TRAINING	0.00	0.00	83.33	0.00	0.00	0.00	1,000.00	0.00
52930-001-6011-055	BOOKS, DUES - SPECIAL OPS	0.00	0.00	100.00	0.00	0.00	0.00	1,200.00	0.00
52930-001-6012-055	BOOKS, DUES - CERT	0.00	0.00	166.67	0.01	0.00	0.00	2,000.00	0.01
52930-001-7000-055	BOOKS, DUES - MEDICAL	225.00	0.01	708.33	0.03	1,675.00	0.01	8,500.00	0.03
<b>Total BOOKS, DUES:</b>		<b>21,409.02</b>	<b>1.36</b>	<b>19,997.91</b>	<b>0.84</b>	<b>67,361.78</b>	<b>0.28</b>	<b>239,975.00</b>	<b>0.84</b>
<b>CAPITAL OUTLAY</b>									
52940-001-0000-062	CAPITAL OUTLAY - BUILDING & IMPRC	0.00	0.00	9,116.67	0.38	53,895.90	0.22	109,400.00	0.38
52940-001-0000-063	CAPITAL OUTLAY - IMPROVEMENTS C	0.00	0.00	708.33	0.03	40,255.60	0.16	8,500.00	0.03
52940-001-0000-064	CAPITAL OUTLAY - EQUIP & FURNISHI	6,561.95	0.42	10,185.58	0.43	151,733.53	0.62	122,227.00	0.43
52940-001-0000-068	CAPITAL OUTLAY - INTANGIBLE ASSE	0.00	0.00	1,633.33	0.07	0.00	0.00	19,600.00	0.07
52940-001-0000-069	CAPITAL OUTLAY - VEHICLES	0.00	0.00	17,416.67	0.73	0.00	0.00	209,000.00	0.73
52940-001-0000-070	CAPITAL OUTLAY - FIRE & RESCUE VE	0.00	0.00	25,000.00	1.05	0.00	0.00	300,000.00	1.05
<b>Total CAPITAL OUTLAY:</b>		<b>6,561.95</b>	<b>0.42</b>	<b>64,060.58</b>	<b>2.69</b>	<b>245,885.03</b>	<b>1.01</b>	<b>768,727.00</b>	<b>2.69</b>
<b>0</b>									
99900-000-0000-000	SUSPENCE ACCOUNT	0.00	0.00	0.00	0.00	252.50	0.00	0.00	0.00
<b>Total 0:</b>		<b>0.00</b>	<b>0.00</b>	<b>0.00</b>	<b>0.00</b>	<b>252.50</b>	<b>0.00</b>	<b>0.00</b>	<b>0.00</b>
<b>Total Expenses:</b>		<b>1,665,831.38</b>	<b>105.48</b>	<b>2,473,766.41</b>	<b>104.05</b>	<b>11,627,923.27</b>	<b>47.64</b>	<b>29,685,197.00</b>	<b>104.05</b>
<b>Net Income from Operations:</b>		<b>-86,596.76</b>	<b>-5.48</b>	<b>-96,289.41</b>	<b>-4.05</b>	<b>12,781,206.79</b>	<b>52.36</b>	<b>-1,155,473.00</b>	<b>-4.05</b>
<b>Earnings before Income Tax:</b>		<b>-86,596.76</b>	<b>-5.48</b>	<b>-96,289.41</b>	<b>-4.05</b>	<b>12,781,206.79</b>	<b>52.36</b>	<b>-1,155,473.00</b>	<b>-4.05</b>



**GNFRD INCOME STATEMENT**  
**For The 4 Periods Ended 1/31/2018**

**Greater Naples Fire Rescue District (GNF)**

	Period to Date	%	ORIGINAL PTD Budget	%	Year to Date	%	ORIGINAL Annual Budget	%
<b>Net Income (Loss):</b>	-86,596.76	-5.48	-96,289.41	-4.05	12,781,206.79	52.36	-1,155,473.00	-4.05

**Balance Sheet  
As of 1/31/2018**

**GNFRD Impact Fee (IMP)**

<b>Assets</b>			
<b>CASH IN BANK</b>			
10100-301-0000-001	IMPACT FEES (IBERAIBANK)	\$ 3,290,666.02	
	<b>Total CASH IN BANK:</b>		\$ 3,290,666.02
<b>DUE FROM OTHER FUNDS</b>			
13100-301-0000-001	DUE FROM GENERAL FUND	\$ 1,000,000.00	
	<b>Total DUE FROM OTHER FUNDS:</b>		\$ 1,000,000.00
	<b>Total Assets:</b>		<u>\$ 4,290,666.02</u>
<b>Equity</b>			
28100-301-0000-001	FUND BALANCE - IMPACT FEES PRIOR YEAR RESTRICTED	\$ 3,548,594.96	
28100-301-0000-002	Retained Earnings-Current Year	\$ 167,370.33	
28100-301-0000-002	FUND BALANCE IMPACT FEES CURRENT YEAR	\$ 574,700.73	
	<b>Total Equity:</b>		\$ 4,290,666.02
	<b>Total Liabilities &amp; Equity:</b>		<u>\$ 4,290,666.02</u>

**Impact Fees Income Statement  
For The 4 Periods Ended 1/31/2018**

**GNFRD Impact Fee (IMP)**

		Period to Date	%	ORIGINAL PTD Budget	%	Year to Date	%	ORIGINAL Annual Budget	%
<b>Revenue</b>									
<b>IMPACT FEES</b>									
32400-301-0000-110	IMPACT FEES	75,359.84	98.34	83,000.00	99.45	259,459.05	97.99	996,000.00	99.45
<b>Total IMPACT FEES:</b>		75,359.84	98.34	83,000.00	99.45	259,459.05	97.99	996,000.00	99.45
<b>GRANTS</b>									
33100-301-0000-200	FEDERAL GRANT - PUBLIC SAFETY	0.00	0.00	0.00	0.00	0.00	0.00	0.00	0.00
33400-301-0000-200	STATE GRANT - PUBLIC SAFETY	0.00	0.00	0.00	0.00	0.00	0.00	0.00	0.00
<b>Total GRANTS:</b>		0.00	0.00	0.00	0.00	0.00	0.00	0.00	0.00
<b>INTEREST EARNINGS</b>									
36100-301-0000-100	INTEREST	1,272.65	1.66	458.33	0.55	5,318.03	2.01	5,500.00	0.55
<b>Total INTEREST EARNINGS:</b>		1,272.65	1.66	458.33	0.55	5,318.03	2.01	5,500.00	0.55
<b>OTHER MISCELLANEOUS INCOME</b>									
36400-301-0000-000	DISPOSITION OF FIXED ASSETS	0.00	0.00	0.00	0.00	0.00	0.00	0.00	0.00
36400-301-0000-001	OTHER MISCELLANEOUS INCOME	0.00	0.00	0.00	0.00	0.00	0.00	0.00	0.00
<b>Total OTHER MISCELLANEOUS INCOME:</b>		0.00	0.00	0.00	0.00	0.00	0.00	0.00	0.00
<b>Total Revenue:</b>		76,632.49	100.00	83,458.33	100.00	264,777.08	100.00	1,001,500.00	100.00
<b>Gross Profit:</b>		76,632.49	100.00	83,458.33	100.00	264,777.08	100.00	1,001,500.00	100.00
<b>Expenses</b>									
<b>IMPACT FEE EXPENSE</b>									
51700-301-0000-071	DEBT SERVICES	1,049.63	1.37	23,821.63	28.54	72,800.19	27.49	285,859.56	28.54
51700-301-0000-072	DEBT SERVICES -INTEREST	0.00	0.00	6,258.33	7.50	19,538.38	7.38	75,100.00	7.50
52200-301-0000-031	PROFESSIONAL SERVICES	0.00	0.00	0.00	0.00	0.00	0.00	0.00	0.00
52200-301-0000-032	FREIGHT	0.00	0.00	0.00	0.00	0.00	0.00	0.00	0.00
52200-301-0000-037	CURRENT CHARGES	0.00	0.00	0.00	0.00	0.00	0.00	0.00	0.00
52200-301-0000-044	RENTAL AND LEASE EXPENSES	0.00	0.00	0.00	0.00	0.00	0.00	0.00	0.00
52200-301-0000-049	SMALL EQUIPMENT AND TOOLS	0.00	0.00	0.00	0.00	0.00	0.00	0.00	0.00
52200-301-0010-046	NEW VEHICLE SMALL PARTS	0.00	0.00	0.00	0.00	0.00	0.00	0.00	0.00
<b>Total IMPACT FEE EXPENSE:</b>		1,049.63	1.37	30,079.96	36.04	92,338.57	34.87	360,959.56	36.04
<b>CAPITAL OUTLAY</b>									
52900-301-0000-061	LAND	0.00	0.00	0.00	0.00	0.00	0.00	0.00	0.00
52900-301-0000-062	BUILDINGS AND IMPROVEMENTS	0.00	0.00	0.00	0.00	0.00	0.00	0.00	0.00
52900-301-0000-063	INFRASTRUCTURE	0.00	0.00	0.00	0.00	0.00	0.00	0.00	0.00

Run Date: 2/5/2018 6:00:14PM  
G/L Date: 1/31/2018

Page: 1

**Impact Fees Income Statement  
For The 4 Periods Ended 1/31/2018**

**GNFRD Impact Fee (IMP)**

	Period to Date	%	ORIGINAL PTD Budget	%	Year to Date	%	ORIGINAL Annual Budget	%	
<b>CAPITAL OUTLAY</b>	(Continued)								
52900-301-0000-064	EQUIPMENT AND FURNITURE	0.00	0.00	5,000.00	5.99	0.00	0.00	60,000.00	5.99
52900-301-0000-065	CONSTRUCTION WORK IN PROGRES:	0.00	0.00	41,666.67	49.93	0.00	0.00	500,000.00	49.93
52900-301-0000-067	SPECIAL RESPONSE TEAMS	0.00	0.00	0.00	0.00	0.00	0.00	0.00	0.00
52900-301-0000-068	INTANGIBLE ASSETS	0.00	0.00	0.00	0.00	0.00	0.00	0.00	0.00
52900-301-0000-069	VEHICLES	0.00	0.00	0.00	0.00	0.00	0.00	0.00	0.00
52900-301-0000-070	CAPITAL OUTLAY-FIRE & RESCUE VEI	0.00	0.00	37,500.00	44.93	5,068.18	1.91	450,000.00	44.93
52900-900-0000-059	DEPRECIATION	0.00	0.00	0.00	0.00	0.00	0.00	0.00	0.00
<b>Total CAPITAL OUTLAY:</b>		<u>0.00</u>	<u>0.00</u>	<u>84,166.67</u>	<u>100.85</u>	<u>5,068.18</u>	<u>1.91</u>	<u>1,010,000.00</u>	<u>100.85</u>
<b>Total Expenses:</b>		<u>1,049.63</u>	<u>1.37</u>	<u>114,246.63</u>	<u>136.89</u>	<u>97,406.75</u>	<u>36.79</u>	<u>1,370,959.56</u>	<u>136.89</u>
<b>Net Income From Operations:</b>		<u>75,582.86</u>	<u>98.63</u>	<u>-30,788.30</u>	<u>-36.89</u>	<u>167,370.33</u>	<u>63.21</u>	<u>-369,459.56</u>	<u>-36.89</u>
<b>Earnings Before Income Tax:</b>		<u>75,582.86</u>	<u>98.63</u>	<u>-30,788.30</u>	<u>-36.89</u>	<u>167,370.33</u>	<u>63.21</u>	<u>-369,459.56</u>	<u>-36.89</u>
<b>Net Income (Loss):</b>		<u>75,582.86</u>	<u>98.63</u>	<u>-30,788.30</u>	<u>-36.89</u>	<u>167,370.33</u>	<u>63.21</u>	<u>-369,459.56</u>	<u>-36.89</u>

**Balance Sheet  
As of 1/31/2018**

**GNFRD Hydrant Fund (HYD)**

---

<b>Assets</b>			
10100-101-0000-001	HYDRANT OPERATING ACCOUNT	\$	437,854.78
	<b>Total Assets:</b>		<u>\$ 437,854.78</u>
<b>Equity</b>			
28200-101-0000-001	FUND BALANCE - HYDRANT ASSIGNED (PRIOR YTD)	\$	401,708.84
28200-101-0000-003	Retained Earnings-Current Year	\$	5,657.80
28200-101-0000-003	FUND BALANCE-CURRENT YEAR	\$	<u>30,488.14</u>
	<b>Total Equity:</b>		<u>\$ 437,854.78</u>
	<b>Total Liabilities &amp; Equity:</b>		<u>\$ 437,854.78</u>

**HYDRANT FUND INCOME STATEMENT**  
**For The 4 Periods Ended 1/31/2018**

**GNFRD Hydrant Fund (HYD)**

	Period to Date	%	ORIGINAL PTD Budget	%	Year to Date	%	ORIGINAL Annual Budget	%
<b>Revenue</b>								
<b>HYDRANT MAINTENANCE INCOME</b>								
32400-101-0000-900 HYDRANT MAINTENANCE	0.00	0.00	0.00	0.00	5,000.00	88.37	0.00	0.00
<b>Total HYDRANT MAINTENANCE INCOME:</b>	0.00	0.00	0.00	0.00	5,000.00	88.37	0.00	0.00
<b>INTEREST EARNINGS</b>								
36100-101-0000-100 INTEREST EARNINGS	167.28	100.00	0.00	0.00	657.80	11.63	0.00	0.00
<b>Total INTEREST EARNINGS:</b>	167.28	100.00	0.00	0.00	657.80	11.63	0.00	0.00
<b>Total Revenue:</b>	167.28	100.00	0.00	0.00	5,657.80	100.00	0.00	0.00
<b>Gross Profit:</b>	167.28	100.00	0.00	0.00	5,657.80	100.00	0.00	0.00
<b>Net Income From Operations:</b>	167.28	100.00	0.00	0.00	5,657.80	100.00	0.00	0.00
<b>Earnings Before Income Tax:</b>	167.28	100.00	0.00	0.00	5,657.80	100.00	0.00	0.00
<b>Net Income (Loss):</b>	167.28	100.00	0.00	0.00	5,657.80	100.00	0.00	0.00



## GREATER NAPLES FIRE RESCUE DISTRICT Operations Report

---

<b>REPORTING OFFICER</b>	Nolan Sapp, Asst. Fire Chief
<b>TYPE</b>	Monthly - Commission
<b>SUBMITTAL DATE</b>	February 7, 2018

**January 2018**

### The Stats:

Total Incidents	2043
Total Responses	2374 (based on all apparatus)
Medical / Rescue	1301 calls for service.
Percentage Medical	63.7%
Fire / Other	742 calls for service.
Busiest Response Unit	EN75 305 Incidents.
Busiest Day of Week	Monday 345 Incidents
Busiest Time of Day	13:00 to 13:59 132 Incidents.

### I attended the following meetings:

- ❖ CCFCA Communications meeting.
- ❖ CCFCA Operations Section meeting.
- ❖ Weekly Executive Command staff meetings.
- ❖ Battalion Chief daily briefings.
- ❖ Labor Management meetings
- ❖ District Strategic Planning
- ❖ Labor Management
- ❖ Work with CCSO CAD/MDT operation meeting.
- ❖ Control West communications
- ❖ Florida Fire Chiefs ELSI Course
- ❖ Regional IMT Steering Committee (Ft. Myers)
- ❖ Regional IMT Team meeting (RSW Airport)
- ❖ CCSO Chief Bloom Incident Command Overview

## Operational Special Events:

- 1-6 Truck Request LA21 and the flag display for Jerry Sanford at New Hope Veterans' Service
- 1-7 Truck Request EN70 at old Kmart Plaza GGPWY for Safety Matters w/CCSO Event
- 1-12 Truck Request EN24 attended National Kindness Week Ceremony at Gulf Coast Charter
- 1-14 Truck Request EN73 attended Temple Shalom Annual Family Picnic
- 1-15 Truck Request EN22 participated in the Martin Luther King Parade
- 1-16 Truck Request EN70 attended and provided a campus visit at Grace Place
- 1-21 Truck Request EN73 attended the Saint Agnes Church Picnic
- 1-26 Truck Request EN75 and LA72 attended Wine Festival
- 1-27 Truck Requested EN20 attended re-grand opening of Naples Preschool Academy
- 1-27 Truck Request LA72 to standby the Swamp Buggy Races
- 1-28 Truck Request EN75 to standby the Swamp Buggy Races



Greater Naples Fire Rescue District Alarm Summary Report / General Type of Assembly

Greater Naples Fire Rescue District	Jan-17	Feb-17	Mar-17	Apr-17	May-17	Jun-17	Jul-17	Aug-17	Sep-17	Oct-17	Nov-17	Dec-17	Total
*NA	2												2
100 Series Fire	44												44
200 Series Overpressure Rupture, Explosion, Overheat(no fire)	1												1
300 Series Rescue & Emergency Medical Service Incident	1301												1301
400 Series Hazardous Condition(No fire)	24												24
500 Series Service Call	122												122
600 Series Good Intent Call	416												416
700 Series False Alarm & False Call	133												133
800 Series Severe Weather													0
900 Series Special Incident Type													0
<b>Grand Total</b>	<b>2043</b>	<b>0</b>	<b>0</b>	<b>0</b>	<b>0</b>	<b>0</b>	<b>0</b>	<b>0</b>	<b>0</b>	<b>0</b>	<b>0</b>	<b>0</b>	<b>2043</b>

Responses by day average	65.9	0.0	0.0	0.0	0.0	0.0	0.0	0.0	0.0	0.0	0.0	0.0	5.5
Average by Stations Daily	6	0	0	0	0	0	0	0	0	0	0	0	0
Average Medical vs. other calls for service (combined)	63.7%	#DIV/0!	#DIV/0!	#DIV/0!	#DIV/0!	#DIV/0!	#DIV/0!	#DIV/0!	#DIV/0!	#DIV/0!	#DIV/0!	#DIV/0!	#DIV/0!

General Types of Assembly Usage	Jan-17	Feb-17	Mar-17	Apr-17	May-17	Jun-17	Jul-17	Aug-17	Sep-17	Oct-17	Nov-17	Dec-17	Total
*NA	3												3
Assembly	69												69
Educational	18												18
Health Care, Detention	264												264
Industrial , Utility, Defense, Agriculture, Mining	1												1
Mercantile, Business	86												86
Outside or Special Property	360												360
Residential	1221												1221
Storage	21												21
<b>GRAND TOTAL</b>	<b>2043</b>	<b>0</b>	<b>0</b>	<b>0</b>	<b>0</b>	<b>0</b>	<b>0</b>	<b>0</b>	<b>0</b>	<b>0</b>	<b>0</b>	<b>0</b>	<b>2043</b>

Mutual Aid / Auto Aid Report # of Incidents

	Jan	Feb	March	April	May	June	July	Aug	Sept	Oct	Nov	Dec	YTD
<b>Mutual Aid Given from GNFD</b>	<b>Incidents</b>												
*NA													0
Bonita Springs Fire													0
City of Naples													0
Florida Forestry Service													0
Immokalee Fire													0
Marco Island													0
North Collier													0
Ochopee													0
Broward County / Dade County	1												1
<b>Total</b>	<b>1</b>	<b>0</b>	<b>0</b>	<b>0</b>	<b>0</b>	<b>0</b>	<b>0</b>	<b>0</b>	<b>0</b>	<b>0</b>	<b>0</b>	<b>0</b>	<b>1</b>
	January	February	March	April	May	June	July	Aug	Sept	Oct	Nov	Dec	
<b>Mutual Aid Received to GNFD</b>	<b>Incidents</b>												
*NA													0
Florida Forestry													0
City of Naples													0
Collier EMS													0
Immokalee Fire													0
Marco Island													0
North Collier													0
Ochopee													0
Broward County / Dade County	1												1
<b>Total</b>	<b>1</b>	<b>0</b>	<b>0</b>	<b>0</b>	<b>0</b>	<b>0</b>	<b>0</b>	<b>0</b>	<b>0</b>	<b>0</b>	<b>0</b>	<b>0</b>	<b>1</b>
<b>Automatic Aid Report</b>													
<b>**Auto Aid Call Data does not include calls we weren't on as well**</b>													
	Jan	Feb	Mar	Apr	May	Jun	Jul	Aug	Sep	Oct	Nov	Dec	YTD
<b>Auto Aid Given</b>	<b>Incidents</b>												
*NA													0
City of Naples	29												29
Florida Forestry Service													0
Immokalee Fire													0
Marco Island	18												18
North Collier	77												77
<b>Total</b>	<b>124</b>	<b>0</b>	<b>0</b>	<b>0</b>	<b>0</b>	<b>0</b>	<b>0</b>	<b>0</b>	<b>0</b>	<b>0</b>	<b>0</b>	<b>0</b>	<b>124</b>
	Jan	Feb	Mar	Apr	May	Jun	Jul	Aug	Sep	Oct	Nov	Dec	
<b>Auto Aid Received to GNFD</b>	<b>Incidents</b>												
*NA													0
Florida Forestry													0
City of Naples	2												2
Collier EMS													0
Immokalee Fire													0
Marco Island	7												7
North Collier	31												31
<b>Total</b>	<b>40</b>	<b>0</b>	<b>0</b>	<b>0</b>	<b>0</b>	<b>0</b>	<b>0</b>	<b>0</b>	<b>0</b>	<b>0</b>	<b>0</b>	<b>0</b>	<b>40</b>

**GREATER NAPLES FRACTILE TRAVEL TIMES**

FROM 1/1/2018 TO 1/31/2018

Unit	< 4 Min	< 5 Min	< 6 Min	< 7 Min	< 9 Min	< 10 Min	< 11 Min	< 12 Min	> 12 Min	Calls
BA20	29.41	58.82	88.24	94.12	94.12	94.12	94.12	94.12	5.88	17
BA70	25.00	31.25	43.75	68.75	87.50	87.50	87.50	87.50	12.50	16
EN20	40.21	63.40	78.35	85.05	93.30	93.81	95.36	96.91	3.09	194
EN21	0.00	20.00	20.00	40.00	60.00	60.00	60.00	60.00	40.00	5
EN22	37.50	54.17	75.00	85.83	93.33	94.17	96.67	97.50	2.50	120
EN23	13.61	14.20	22.49	33.14	55.03	65.68	72.19	79.29	20.71	169
EN24	23.46	41.98	61.73	76.54	91.36	92.59	95.06	97.53	2.47	81
EN60	36.00	40.00	40.00	48.00	64.00	80.00	80.00	80.00	20.00	25
EN61	37.50	50.00	75.00	81.25	81.25	81.25	81.25	81.25	18.75	16
EN70	36.13	61.94	80.65	88.39	96.13	98.06	98.06	98.71	1.29	155
EN71	12.37	23.71	32.99	48.45	64.95	72.16	78.35	85.57	14.43	97
EN72	10.89	17.82	33.66	51.49	74.26	87.13	93.07	94.06	5.94	101
EN73	14.58	27.08	44.79	60.42	80.21	83.33	89.58	91.67	8.33	96
EN75	20.54	37.60	59.30	74.03	91.09	93.80	94.96	96.12	3.88	258
EN90	15.00	22.50	37.50	45.00	77.50	85.00	87.50	87.50	12.50	40
LA21	22.50	35.83	50.00	65.83	83.33	90.00	91.67	93.33	6.67	120
LA72	4.35	8.70	17.39	21.74	60.87	65.22	69.57	73.91	26.09	23
RE63	22.22	33.33	44.44	44.44	77.78	77.78	77.78	77.78	22.22	9
RE70	0.00	0.00	100.00	100.00	100.00	100.00	100.00	100.00	0.00	1
RE72	0.00	50.00	50.00	50.00	50.00	50.00	50.00	100.00	0.00	2
SQ21	30.30	37.37	55.56	67.68	85.86	91.92	94.95	95.96	4.04	99
SQ76	11.65	25.24	55.34	72.82	92.23	97.09	98.06	98.06	1.94	103

### Apparatus Response Report

	Jan-17	Feb-17	Mar-17	Apr-17	May-17	Jun-17	Jul-17	Aug-17	Sep-17	Oct-17	Nov-17	Dec-17	Total	YTD
AIR 72													0	0.00%
AT 23	6												6	0.25%
AT 60	1												1	0.04%
AT 63	10												10	0.42%
AT 90													0	0.00%
BA 20	85												85	3.58%
BA 60	2												2	0.08%
BA 70	78												78	3.29%
BO60													0	0.00%
BO 90	3												3	0.13%
BR 21	5												5	0.21%
BR 22	4												4	0.17%
BR 70													0	0.00%
BR 71	6												6	0.25%
BR 72	5												5	0.21%
BR 73	1												1	0.04%
CA 22													0	0.00%
CA 70	3												3	0.13%
CH 20													0	0.00%
CH 23													0	0.00%
CH 72	5												5	0.21%
EMS 25	4												4	0.17%
EN 20	237												237	9.98%
EN 21	6												6	0.25%
EN 22	153												153	6.44%
EN 23	230												230	9.69%
EN 24	128												128	5.39%
EN 60	30												30	1.26%
EN 61	23												23	0.97%
RE 63	21												21	0.88%
EN 70	171												171	7.20%
EN 71	110												110	4.63%
EN 72	113												113	4.76%
EN 73	131												131	5.52%
EN 75	305												305	12.85%
EN 90	63												63	2.65%
LA 21	151												151	6.36%
LA 72	38												38	1.60%
PU 21													0	0.00%
PU 22													0	0.00%
RE 72	2												2	0.08%
SQ 20													0	0.00%
SQ 21	108												108	4.55%
SQ 72	5												5	0.21%
SQ76	110												110	4.63%
WT 20	8												8	0.34%
WT60	1												1	0.04%
WT63													0	0.00%
WT 70													0	0.00%
WT 71	12												12	0.51%
<b>Total Resp.</b>	<b>2374</b>	<b>0</b>	<b>0</b>	<b>0</b>	<b>0</b>	<b>0</b>	<b>0</b>	<b>0</b>	<b>0</b>	<b>0</b>	<b>0</b>	<b>0</b>	<b>2374</b>	

### APPARATUS RESPONSES

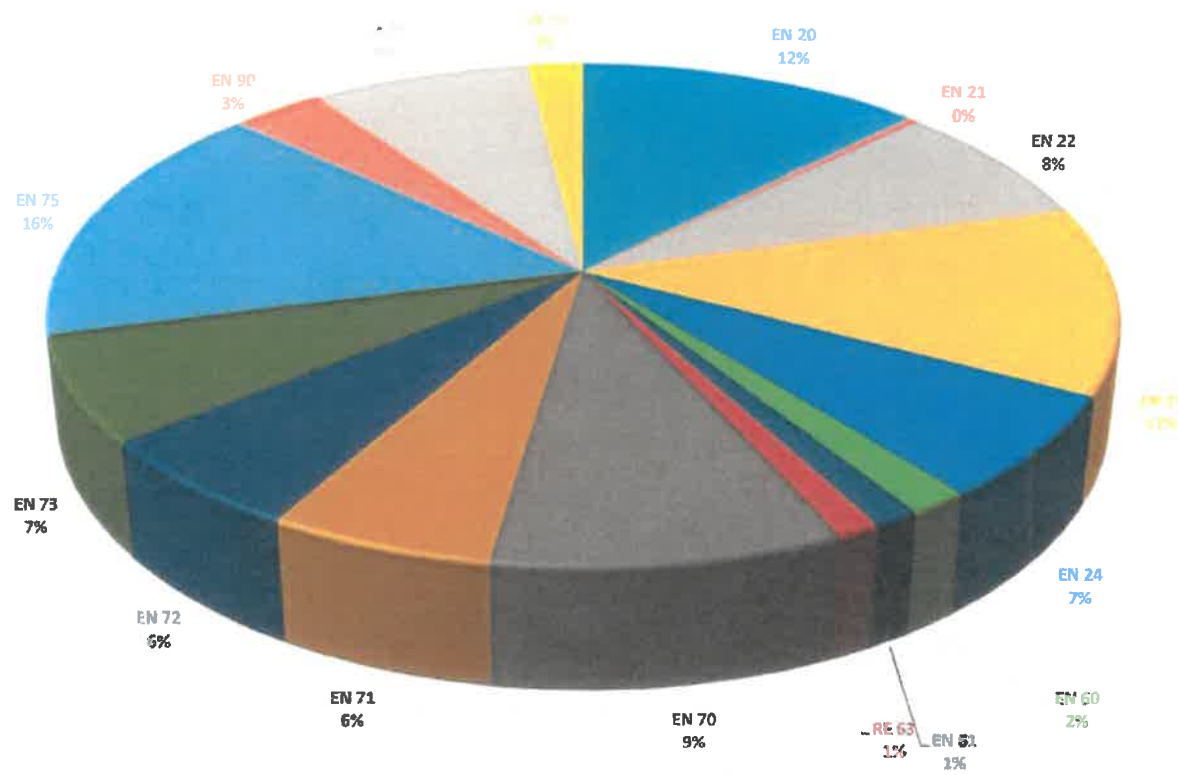

Day of Week / Shift Numbers / Time of Day Report of Incidents

WEEK RPT	Jan	Feb	Mar	Apr	May	Jun	Jul	Aug	Sep	Oct	Nov	Dec	Total	
Sunday	278												278	14.03%
Monday	345												345	17.42%
Tuesday	325												325	16.41%
Wednesday	250												250	12.62%
Thursday	241												241	12.17%
Friday	261												261	13.18%
Saturday	281												281	14.18%
													1981	100.00%
SHIFT	Jan	Feb	Mar	Apr	May	Jun	Jul	Aug	Sep	Oct	Nov	Dec	Total	
A-Shift	652												652	31.93%
B-Shift	674												674	33.01%
C-Shift	716												716	35.06%
													2042	

Hour of Day	INC
0:00	48
1:00	49
2:00	30
3:00	36
4:00	41
5:00	42
6:00	56
7:00	71
8:00	114
9:00	111
10:00	119
11:00	126
12:00	88
13:00	132
14:00	106
15:00	114
16:00	104
17:00	104
18:00	107
19:00	109
20:00	83
21:00	66
22:00	71
23:00	54

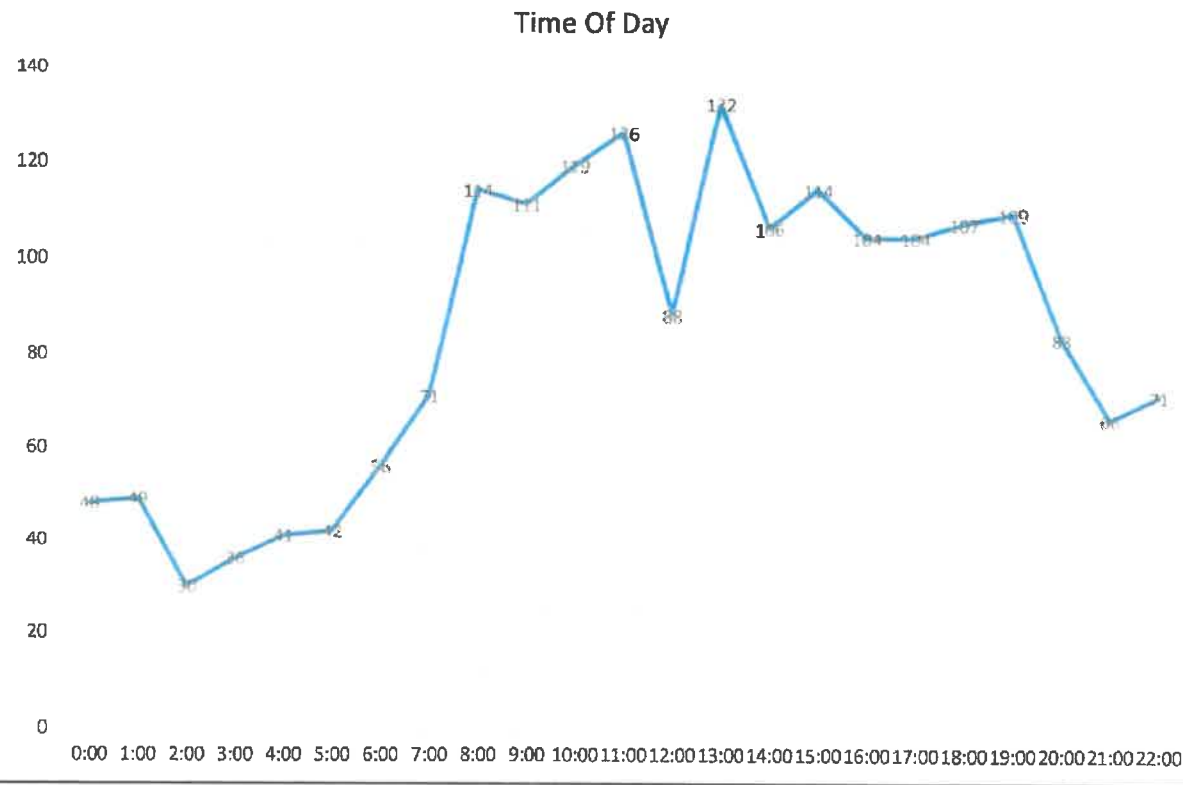



# GREATER NAPLES FIRE RESCUE DISTRICT

## Administration and Finance Report

<b>REPORTING OFFICER</b>	Tara Bishop, Deputy Director
<b>TYPE</b>	Monthly - Commission
<b>SUBMITTAL DATE</b>	February 1, 2018

**January 1 to January 31, 2018**

**1. Administration:**

- Completer the FFCA ESLI Class Series
- Participated in Compensation Study Meeting
- Attended International Fellowship Program Meetings
- Participated in ISO Meetings
- Weekly FEMA coordination / check in
- Participated in Station Supply Meeting
- Attended Mitigation Recovery Project Planning Meeting
- Coordinated the VFIS Risk Management Site Visit
- SmartDoc’s Adobe Connect System Training on-lie demonstration
- Preparations of Board Meetings, Agenda and Packet
- Filled 29 public records requests
- Coordination of meeting room reservations
- Processed class funding and travel paperwork
- Daily office operations; mail distribution, walk in traffic interactions and guidance to needed staff Weekly, bi-weekly, monthly review of general ledger, weekly attendance, payroll, monthly purchase report, etc. Attended weekly staff/division and monthly BOFC meetings.

**2. HR Specialist:**

- Number of new W/C claims: 1 New , 2 Continuing
- FMLA – 0 New, 0 Continuing Short Term Disability – 1 New, 1 Continuing
- Job Posting current: F/T & P/T Firefighter, Administrative Assistant 11/29/17
- New Hires: 0, Retiree: 0, Terminations: 3
- Facilitated New Firefighter Interview process – 26 Applicants
- Annual Physical Exams: 2 Employees to schedule due to absences
- I-9 Internal Audit – ongoing, prepare procedure for advancing comprehensive audit
- Process Medicare payments 1 sign up
- Attend Program – Opioid Addiction in the workplace
- Webinar - Using People Science to Grow your Organization

**3. Finance:**

- Cross trained on payroll and deposit entry between Pat and Mercedes
- Completed Form 941- 4<sup>th</sup> Quarter, Tied 2017 941 Forms to the W-2’s
- Complied and Sent W-2 File to Aatrix- the company which submits Federal Forms
- Completed and mailed Form 720 4<sup>th</sup> Quarter for the Foundation
- Worked on Payroll Information for ISO Report
- Set up new account numbers in General Ledger as needed and relayed information to IT to update FileMaker Pro and notified all personnel that would need new information



## GREATER NAPLES FIRE RESCUE DISTRICT Planning Section Report

<b>REPORTING OFFICER</b>	Wayne Martin, Deputy Director
<b>TYPE</b>	Monthly- Fire Commission
<b>SUBMITTAL DATE</b>	February 1, 2018

**January 1, 2018 to January 31, 2018**

Meetings, Training, Conference, Special Events:

- \* Participated in Command Staff Meetings
- \* Facilitate Strategic Planning Meeting
- \* Attended January BOFC Meeting
- \* Attend CC Fire and EMS Chiefs Association
- \* Participant CCFEMSCA Data Committee
- \* Attended Informational & Planning Mtg. for International Fellowship Program
- \* Participant Fire Districts Merger Meetings
- \* Attended Collier County Task Force Meeting
- \* Attended Labor Management Meeting
- \* Participant ISO meetings
- \* Attended District Safety Committee Meeting
- \* Attended Public Safety Meeting
- \* Participant Golden Gate Community Parade Planning Meeting
- \* Attended Community of Faith Meeting
- \* Attend Budget Review meeting

Projects:

- \* Serve as Fire District Duty Officer
- \* Coordinated Pre build conference REV E-One
- \* Updated Chief Duty Officer Handbook
- \* Quotes secured for Fleet Purchases
- \* Track District Pool Vehicles
- \* Edited GNFD Master Calendar
- \* Updated GNFD Phone list
- \* Edited SOG's
- \* Fleet continues to work on District PM program
- \* Fleet updates being sent weekly
- \* Apparatus standardization program Engine 20
- \* Sent out receipts for Fire Foundation donations
- \* Updated FY 2017-2018 Purchasing timeline
- \* Review ISO
- \* Daily Office operations; walk in traffic, mail distribution, deliveries & distribution of packages
- \* Reconciled WEX card receipts for pool and Planning vehicles
- \* Sign In/Out of District Pool Vehicles
- \* Assist accounting with paycheck distribution and expense checks
- \* Prepared agenda packet for Ochopee Fire Advisory Meeting February 2018





## **GREATER NAPLES FIRE RESCUE DISTRICT Planning Section Report**

- \* Worked with vendor for logo for GNFD Fire Foundation
- \* Assisted HR section with interview schedule
- \* Assisted Accounting with sending out vendor checks (Jan)
- \* Obtained Certificates of Liability for Director Bishop
- \* Set up program to distribute 2018 Staff Vehicle & Apparatus insurance cards
- \* Formatted nine SOGs to GNFD Standard
- \* Prepared Ochopee Advisory Committee Letter of Recommendation
- \* Sent Subpoenas to Fire Personnel along with incident report's
- \* Prepared Notice of Public Meeting for Ochopee Advisory Committee meeting
- \* Set up with vendor two vending machines for Greater Naples Fire Foundation



## GREATER NAPLES FIRE RESCUE DISTRICT Logistics Section Report, Facilities Branch

<b>REPORTING OFFICER</b>	Alan McLaughlin, Deputy Chief
<b>TYPE</b>	Monthly- Commission
<b>SUBMITTAL DATE</b>	February 7, 2018

**January 1 to January 31, 2018**

### **Meeting, Training, Conference, Special Events:**

- \* Participated in all Staff Meetings
- \* Participated in General Staff Meeting
- \* Participated Section Managers Meeting

### **Projects: Completed:**

- \* Station 23 interior rebuild
- \* LDH 5" conversion completed
- \* Grainger station order process completed
- \* Fire extinguisher inspection completed
- \* Ferrel gas continuity project completed
- \* Engine 20 standardization completed with Fleet

### **Projects: In Process:**

- \* Station equipment identification in process
- \* Bay door opener and safety stop project in process
- \* Station 20 Phase One remodel on hold
- \* Equipment asset control and inventory in process
- \* Station site security in process
- \* Apparatus intake valve standardization and replacement in process
- \* Nozzle standardization in process
- \* Station maintenance program in final review
- \* High Rise pack replacement in process
- \* Station 90 boat lift repair bids reviewed in process
- \* Station 90 roof repair awarded and in process
- \* Station 72 and 20 roof repair in bid process
- \* Auction of removed assets in process



## GREATER NAPLES FIRE RESCUE DISTRICT Training and Special Operations Report

REPORTING OFFICER	Rob Low, Deputy Chief
TYPE	Monthly- Commission
SUBMITTAL DATE	February 6, 2018

### January 1 thru January 31, 2018

During the month of January the training and special operations section completed the following benchmarks in support of district personnel:

- **Dive Team-**  
Discussion were held to strategize a path forward to better align our dive team members with other agencies within the County. As a result, a plan was put into place to initially get four members trained at the instructor level followed by training for all dive team members. Additionally, the special operations branch will be looking at recruitment of personnel to fill existing team vacancies. The EMS Training Branch successfully graduated seven personnel from the ALS academy program.
- **Target Solutions-**  
The District's training management system/database enhancements continue as all training records are being converted to electronic files.
- **Drills/Exercises-**
  - *Brush Fire-* In preparation for brush fire season, the training branch conducted a chainsaw and fire shelter training for on-duty personnel. This training was followed by brush truck operations in which personnel had the opportunity to drive brush vehicles off-road. The Collier County Sheriff Office brought in their "new" helicopter and the Department of Forestry brought in one of their dozer/plow units. This allowed personnel to become familiar with other agencies/resources that are used in support of wildfire season.
  - *Shift Training-* Battalion Chiefs Trent and Krajewski put together an incident command accountability class for their shift personnel. This class was delivered on duty with more than 40 personnel attending the 1.5 hours sessions.
- **Health and Safety-** The Health and Safety Branch continues to support the district with reviewing employee incidents and making recommendations for preventative measures with a focus on employee health and safety.
- **Section Personnel-** Lieutenant Cotter attended the annual Fire Rescue East conference held in Daytona Beach. While there he was able to attend numerous breakout sessions regarding current EMS issues and networked with EMS professionals from around the State.



# GREATER NAPLES FIRE RESCUE DISTRICT

## Investigative Section/Fire & Life Safety Report

<b>REPORTING OFFICER</b>	Shawn M. Hanson, Deputy Chief
<b>TYPE</b>	Monthly
<b>SUBMITTAL DATE</b>	January 30, 2018

**December 1 through December 31, 2017**

### Inspection Statistics

Permitted Inspections: 344

Occupational/Business Tax License Inspections: 30

Annual Inspections: 46

Other Inspections: 251

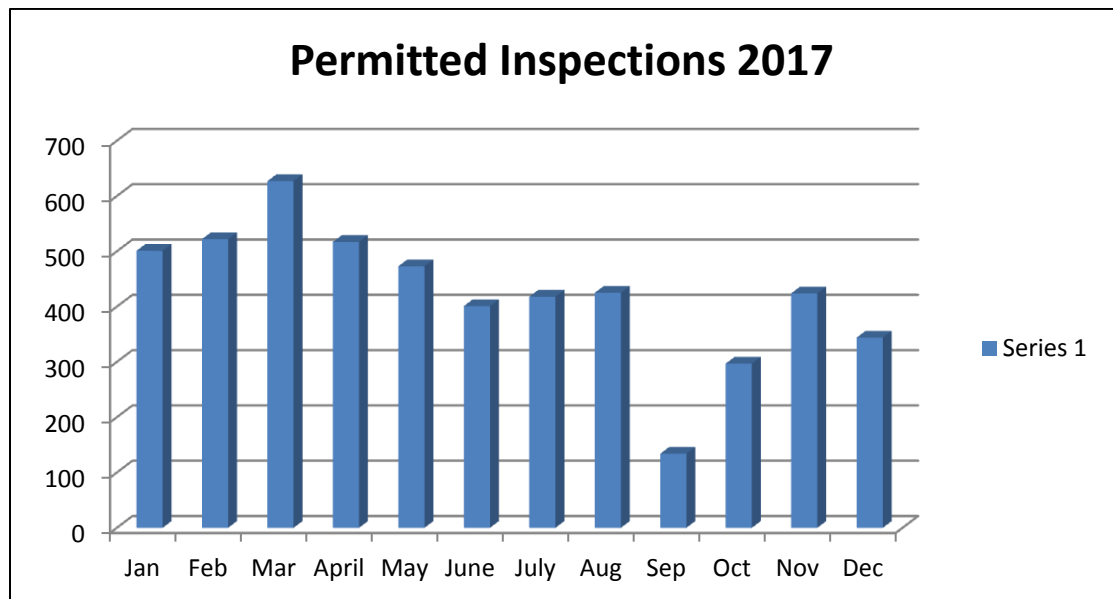



## GREATER NAPLES FIRE RESCUE DISTRICT Investigative Section/Fire & Life Safety Report

Average wait time for an inspection in December: 1 - 2 Days

Current wait time as of January 30<sup>th</sup>: 2 - 3 Days

35 hours of overtime were utilized in December for overflow inspections and 6 hours for a fireworks show at Fiddler's Creek.

### **Fire Plan Review Statistics**

Fire Plan Building Reviews: 446

- increase of 117 from November

\*each review generates a minimum average of 3 field inspections

Site Development/Planning Reviews: 63

- increase of 15 from November

Average Review Time: 3 Days

### **Pending Projects From Site Development Meetings**

- Proposed Vanderbilt Reserve on Rockefeller Wey; 200 single family homes
- Proposed 90,000 square foot rezoning of property located at 7550 Immokalee Road, 8245 and 8251 Logan Blvd for the development of commercial use
- Union Way (Port of the Islands) site development for a 12 unit multi-family building located at the end of the current paved terminus of Union Way.
- New Hope Ministries located at 7576 Davis Blvd; - the proposed project includes the development of five multi-family buildings totaling 304 units.
- Arboretum on Thompson Drive; proposed 244 residential units on the 37 acre site
- Moorings Park at Grande Lake located on the East side of Airport Pulling Rd; phase one to include eleven 6-story Independent Living Facilities mid-rises (over parking) totaling 164 units. Project to contain 16 Independent Living Facilities with 275 total living units and a 200,000 + square foot clubhouse
- 25,248 square foot Aldi Store within Countryside Shopping Center off Santa Barbara Blvd
- Azure at Hacienda Lakes - Rattlesnake east of Collier - This phase of the project consists of 56 units (14 multi-family, 4 unit buildings)
- Shell constructions of a 29,843 SF retail facility at Logan Landing off Immokalee Rd
- Revised building and parking footprint for Trio
- Proposed 13,000 SF retail space, Trio Residential Hotel Shoppes, on the ground level of Trio
- Proposed 105,318 SF 3-story storage facility on Rattlesnake-Hammock
- Proposed Staybridge Suites Hotel consisting of 91 – 106 rooms off Celeste Dr
- Proposed construction of a new clubhouse within Naples Estates



## **GREATER NAPLES FIRE RESCUE DISTRICT**

### **Investigative Section/Fire & Life Safety Report**

#### **Special Events/Public Education**

No Special Events/Public Education

#### **Investigations**

Two incidents required assistance from the Investigative Section in the month of December.

IS staff hours: 10.5 hours

#### **AHJ Report**

- IS Investigative (IS) staff attended and facilitated the CCFMA (Collier County Fire Marshals) meeting
- IS staff members participated in Target Solutions training
- IS staff members attended and participated in classes, committees and other training, including OMD training, Water-Based Systems Committee meeting, Fire Alarm Committee meeting and Public Education Committee meeting
- IS staff attended the Collier County Task Force meetings
- IS staff attended the DSAC meeting at Collier County Growth Management (GMD)
- Participated in the Strategic Planning activities
- Participated in the Governing Documents Committee activities
- IS staff participated in meetings for plan review items, variance requests, deficiency form requests, site development concerns and other issues
- IS staff assisted with Fire Plans Reviewer interviews at Collier County GMD
- Participated in Florida Fire Sprinkler Coalition activities
- Participated in FFMIA Legislative Committee activities
- IS staff attended the CCFMA Public Education Committee meeting
- IS staff participated in FFMIA Executive Board activities
- Participated in IAFC Diversity Executive Leadership Program (iDELP) activities
- Participated in NFPA Technical Committee activities
- Ongoing cross-training inspectors
- IS staff participated in Labor Management meetings
- Participated in the Collier County Fire and EMS Chiefs Association meeting
- IS staff participated in Health and Safety Committee activities
- Attended the CCFMA Bylaws Committee update meeting
- Attended meeting with Public Utilities regarding new and existing hydrants
- IS staff participated in the Verona Walk Wildland Fire Mitigation Meeting
- IS staff participated in ISO preparation activities and ISO survey

Greater Naples Fire Rescue District  
Disposition of Fixed Assets  
# 18-004

To: Board of Fire Commissioners		Date: 02/06/2018					
Inventory No.	Qty.	Description	Condition	Age (years)	Comments Disposal Method	Location	Org Cost
3645	1	SCBA Bottle Clamp	Broken	8	Trash		\$40.33
3679	1	Panasonic MDT	Broken	7	Trash		\$1,687.74
4219	1	Television	Broken	13	Trash		\$1,379.99
237	1	Piston Intake	Broken	28	Auction		\$712.00
651	1	Hurst Tool	Broken	21	Auction		\$5,077.00
660	1	Hurst Tool	Broken	21	Auction		\$3,743.00
1786	1	PPV Fan	Broken	14	Auction		\$1,801.00
130	1	PPV Fan	Broken	28	Auction		\$1,250.00
3438	1	PPV Fan	Broken	10	Auction		\$1,580.00
824	1	Nozzle	Outdated	19	Auction		\$506.00
2938	1	Nozzle	Outdated	11	Auction		\$270.63
1856	1	Nozzle	Outdated	14	Auction		\$535.15
1987	1	Nozzle	Outdated	14	Auction		\$290.00
2936	1	Nozzle	Outdated	11	Auction		\$270.63
1853	1	Nozzle	Outdated	14	Auction		\$535.15
1854	1	Nozzle	Outdated	14	Auction		\$535.15
1847	1	Nozzle	Outdated	14	Auction		\$535.15
1848	1	Nozzle	Outdated	14	Auction		\$535.15
636	1	Nozzle	Outdated	19	Auction		\$548.50
EN3047	1	4"x3-2.5" WYE	Fair	14	Auction		\$600.00
EN3054	1	Nozzle	Fair	14	Auction		\$525.00
EN5026	1	Panasonic MDT	Broken	8	Trash		\$1,687.74
<b>Total:</b>							<b>\$24,645.31</b>

Reviewed by: Tara Bishop  
Prepared by: Sarah Pike

Date: 02/08/2018  
Date: 02/06/2018

We, the undersigned, certify that the property items listed on this form are in the stated condition and warrant disposition.  
Motion to dispose of listed property offered by Commissioner \_\_\_\_\_, seconded by Commissioner \_\_\_\_\_.  
Motion passed by a vote of \_\_\_\_ to \_\_\_\_\_. Signed this 13th day of February 2018.

\_\_\_\_\_  
Commissioner Jeff Page

\_\_\_\_\_  
Commissioner Steve Hemping

\_\_\_\_\_  
Commissioner Kevin Gerrity

\_\_\_\_\_  
Commissioner Robert A. Boyer

\_\_\_\_\_  
Commissioner David Stedman

\_\_\_\_\_  
Commissioner Brian Cross

\_\_\_\_\_  
Commissioner Charles Cottiers

\_\_\_\_\_  
Commissioner Tom Henning

From: Zen Hunter Ishikawa  
Sent: Tuesday, January 30, 2018 11:49 AM  
To: John Bigica  
Cc: Shawn Hanson  
Subject: Re: Plan Reviewer Contact

Dear John:

Thank you for this and for everything. You have been an amazing inspector with both your strong ethical compass and your comforting and positive attitude. We will expeditiously address the 3 items you identified and get back to you ASAP.

GNF is lucky to have you on their team! Hope to see you in the restaurant as a customer soon.

We will be in touch with Tom to expect the updated alarm drawings also.

--

Zen Hunter-Ishikawa





# GREATER NAPLES FIRE RESCUE DISTRICT FIRE CHIEF REPORT

JANUARY, 2018

REPORTING OFFICER	Kingman Schuldt, Fire Chief
TYPE	Monthly – Commission
SUBMITTAL DATE	February 6, 2018

## ACTIVITIES REPORT

Awards – Lieutenant Inspector John Bigica was awarded the Florida Fire Chiefs’ Association Fire Inspector of the Year Award during the 2018 FFCA Conference in Daytona Beach.

Legislative – Staff remains engaged in several significant legislative items occurring in Tallahassee. On January 24<sup>th</sup> Representative Sprowls withdrew Proposal 69 from the Finance & Taxation Committee of the Constitution Revision Commission. The original intent of the proposal was to protect and empower property tax payers by providing for the expiration of the authority of special districts to levy ad valorem taxes unless voter approval to levy such taxes was obtained every 10 years. There remains concern that Representative Sprowls may have intentions to approach consideration as a statutory enactment by the Florida Legislature.

As a result of efforts in Tallahassee to secure funding for the FDOT MM 63 fire station the District presented a letter to Governor Scott requesting his attention to the matter. I am continuing communications with our local legislators and the Collier County Governmental Affairs to gain support for the program. Currently there remains some push back from FDOT officials. I travelled to Tallahassee twice in recent weeks to testify during Senate Committee Hearings in favor of the Bills presented.

Community of Faith Meeting – Staff continues to work with Collier County Commissioner Penny Taylor to develop a program that will utilize various local religious institutions to assist with relief efforts during times of disaster. GNFD recently hosted a meeting where more than 30 representatives from local churches gathered to discuss the program. As a result, GNFD is establishing a smaller group of individuals from churches within the fire district to begin addressing the program. Chaplain Jack is assisting with the effort.

Community Emergency Response Team – Staff met with VeronaWalk CERT team leader Barry Gerenstein to discuss local CERT efforts and the expansion of the program. I also met with North Collier Fire Chief Cunningham on ways to bring the CERT efforts together. We have identified a number of options to enhance the programs including a potential funding source.

North Collier Collaboration – Effective February 15 GNFD and NCFD will begin a Station 24/47 joint staffing initiative. A six-month rotation will commence with NCFD staffing the station and GNFD assuming staffing responsibilities on August 1. As a result of this initiative the Union has demanded to bargain said changes.



## GREATER NAPLES FIRE RESCUE DISTRICT FIRE CHIEF REPORT

Budget Management - As part of Staff's budget management efforts the District is now addressing six potential (or in progress) alternative funding strategies to off-set current expenditures. Areas include CERT, Training, Fire Prevention and Safety, and Public Education, Interns, and Local Mitigation Strategy.

- FEMA AFG – Training equipment valued at \$700,000.00 with a 10% match
- Factory Mutual (FM) Global - Public education materials. Value undetermined and 100% funded
- SFMO Firefighter Decon – Haz Mat decon equipment. Valued at \$10,000.00 and 100% funded
- FEMA FPS – Residential smoke detector program. Under development, 10% match, value not determined yet but early estimates at approximately \$25,000.
- CERT – Team equipment and training. 100% funded, under development
- LMS – Infrastructure enhancements, facility generator replacement. 100% funding potential.

Staff continues to review current budget allocations and priorities for the remainder of the fiscal year. Capitol project are being reprioritized, all expenditures are being reviewed and justified, overtime limited to necessary and essential services, specialty team expenses limited and continued collaboration with North Collier to maximize resources.

District Interns – Staff met with the Greater Naples Chamber of Commerce to discuss hosting student interns. This is part of the District's efforts to fill needed positions without negatively impacting the current budget. Grant funding is available from the Chamber of Commerce and staff is currently developing a job description for an intern position for Communications and Public Affairs. If successful, this position will work 20 hours per week, under direction of the Fire Chief, Addressing our public outreach efforts such as newsletters, annual reports, public information campaigns, and social media outreach for example.

ISO – On February 5, staff submitted a letter to ISO as part of the voluntary effort to increase the District's PPC. Staff has entered into an approximate six-month period to provide additional data for review by ISO.

Facilities – Station 23 was reopened on Friday, February 2. Crews assisted to prepare the facility throughout the week prior and continue to assist with the move-in process. Station 60 is nearing completion with an anticipated move-in the second week of February.

Station 70 remains an issue with the re-infestation of termites. For nearly a month the County has been non-responsive to address the issue. Staff met with the County Manager on February 6 to request immediate attention to the matter.

Ochopee Management Agreement - I also met with the County Manager to discuss the current Agreement, terms and conditions, and transfer of apparatus and equipment to the District.



## GREATER NAPLES FIRE RESCUE DISTRICT FIRE CHIEF REPORT

Apparatus - The new, Emergency One fire engine (demo unit) was delivered on February 8. Equipment has been mounted and training expected to be complete by February 16. The unit will be placed in-serve thereafter.

Two new Battalion Chiefs vehicles arrived in Ocala earlier this month. Build out is expected to be complete in approximately 45 days.

Personnel – Human Resources recently facilitated 28 interviews for the current Apprentice Firefighter vacancies. 11 applicants have been moved forward for the Fire Chief's interview currently under way. Three other current vacancies (AA, Warehouse Tech, Training Specialist) are not being addressed at this time.

International Fellowship Program – An informational meeting was recently held with about a dozen members attending. All materials presented during the informational session was additionally provided to the Union for informational purposes. Several members have requested to be a part of the Fellowship Team and assist in various aspects of the program. Staff also met with the Miami-Dade Fire Rescue Program Director who has been assigned as our mentor for the project.

Foundation Activity – A distribution of nearly \$42,000.00 was made to our two firefighters displaced by Hurricane Irma. Additional fundraising took place during the recent Seafood Festival in Everglades City.

Upcoming Travel  
None scheduled

Public Programs  
13 Events in January  
9,853 Contacts in January

13 Events YTD  
9,853 Contacts YTD

Customer Satisfaction Surveys  
Emergency Response- 2  
Fire & Life Safety- 1  
Administrative- 3



# GREATER NAPLES FIRE RESCUE DISTRICT FIRE CHIEF REPORT

## MEETINGS AND EVENTS

- Participated in the following teleconferences as board or committee member for the following organizations:
  - Southeastern Association of Fire Chiefs
  - EMS Advisory Council
  - Disaster Response Committee
- Meetings
  - Weekly Command Staff
  - Everglades City Council
  - International Fellowship Program
  - ISO
  - North Collier Merger
  - GG Civic Association
  - Chamber of Commerce Public Policy Committee
  - EMS Advisory Council- Daytona Beach, FL
  - MM63 Bill Hearing- Tallahassee, FL
  - Fully Involved
  - Community of Faith
  - CC Fire & EMS Chiefs' Association
  - SEAFC Winter Boar Meeting- Murfeesboro, TN
  - Commissioner Fiala Town Hall



# Fill the Boot

## A Partnership for Strength, Independence & Life

Every day, kids and adults are diagnosed with muscular dystrophy, ALS and related life-threatening diseases that take away their ability to walk, run, hug, dress themselves, talk and even breathe. There are currently few treatments and no cures. The Muscular Dystrophy Association (MDA) and the International Association of Fire Fighters (IAFF) are working to change that.

### It's a Lifesaving Tradition

Since 1954, IAFF has supported MDA with unwavering drive and relentless passion. We're proud to have the IAFF as our largest national partner and are thankful for the thousands of fire fighters who have participated in Fill the Boot drives across America, as well as those who have volunteered countless hours at MDA Summer Camps. And until a cure is found, we'll be filling those boots together.

### How do Fill the Boot donations change lives?

Every coin and every dollar placed in a fire fighter's boot for MDA helps local families living with muscular dystrophy today.

#### Funding research for new treatments

In the last two years, six promising new drugs received FDA approval.

#### Supporting MDA Care Centers

MDA gives families access to best-in-class doctors and specialists all in one location.

#### Sending kids to MDA Summer Camp

Each year, the money you raise through Fill the Boot helps give more than 3,800 kids a life-changing week at MDA Summer Camp, at no charge to their families.



## Mark Your Calendar

### Local 2396 Fill the Boot Event!

February 23—3pm - 6pm Location: Pine Ridge Road & Logan Boulevard  
February 24—9am - 1pm Location: Vanderbilt Beach Road & Logan Boulevard



Muscular Dystrophy Association of Southwest Florida

For more information, please contact Cindy Nichols  
(239) 437-6900 or cynichols@mdausa.org





**GREATER NAPLES FIRE RESCUE DISTRICT  
BOARD OF FIRE COMMISSIONERS  
Agenda Item**

**NEW BUSINESS**

**Agenda Item:** III. A.  
**Subject:** Squad 76  
**Meeting Date:** February 13, 2018  
Commissioner Gerrity

---



# GREATER NAPLES FIRE RESCUE DISTRICT

## MEMORANDUM

**DATE:** February 8, 2018  
**TO:** Kingman Schuldt, Fire Chief  
**FROM:** J. Nolan Sapp, Assistant Fire Chief  
**SUBJECT:** Squad 76 statistical run data

---

Squad 76 (a single resource unit) is located at the intersection of Vanderbilt Beach Rd. and Logan Blvd. Their primary responsibility is to provide ALS capable medical response based on Closest Unit CAD Response to the citizens in proximity to their station or given location. They are based in a heavy duty pickup for rapid response, equipped with ALS medical equipment, light tactical hand tools and an array of portable extinguishers.

SQ76 is primarily a medical response unit, but they also respond to an array of reported emergencies. They are used to support all aspects by boosting our two-in-two-out fire attack protocol. They can respond to provide Water Tender operations to Stations 71 and 70 by allowing an intact crew of three remain on the engines and they assume the water supply role. They also respond to I-75 to augment the response levels on that highway when needed.

SQ76, SQ21 and SQ72 are incorporated in our response algorithm for responses to residential, commercial and high rise structure fires. The additional personnel allow us to strive to meet the optimal number of Firefighters arriving within NFPA1710 guidelines.

SQ76 went into service on May 1, 2017. To date they have responded to:

- 625 calls for service either as a single resource or as a part of an alarm assignment
- SQ76 has been assigned 536 incidents as either first due or single resource unit
- Of the incidents where a Collier County Medic unit was dispatched, SQ76 arrived first on scene 51% of the time
- SQ76 responded as an Automatic Aid unit to external partners 133 times of the 536 incidents

SQ76 provides a variety of roles and fills voids that occur during the daily mission to provide the best in coverage across the District. Squads allow us to minimize the number of times larger apparatus have to respond, and the vehicle type allows better maneuverability while responding to the scene.

\*\*\*

### SQ76 Time Of Day

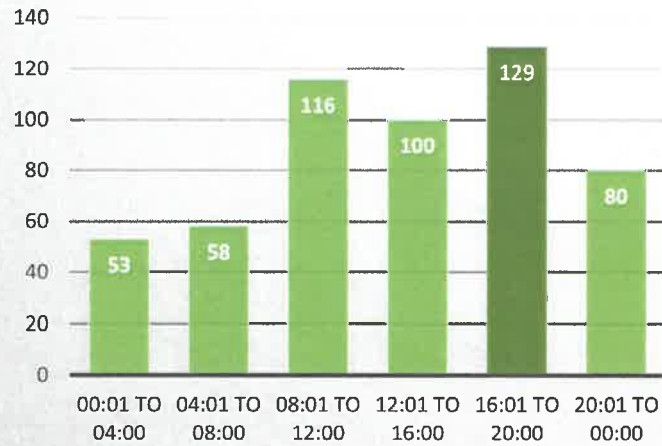

### SQ76 Day Of Week

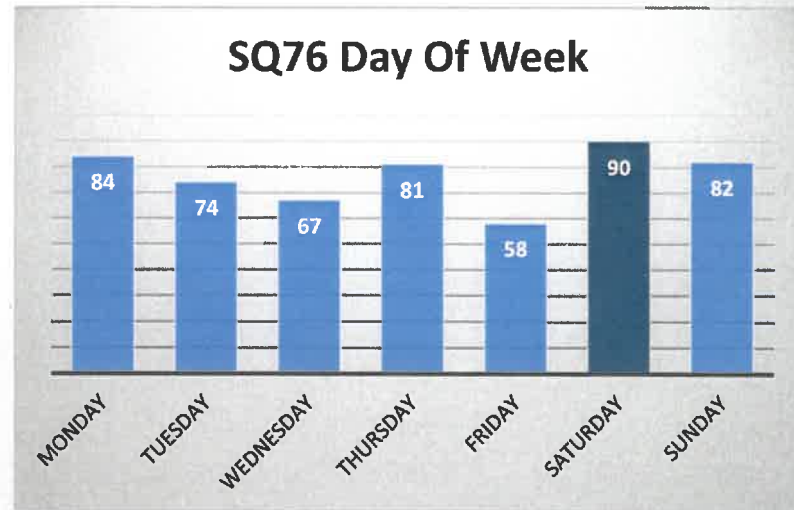

### SQ76 Response Types

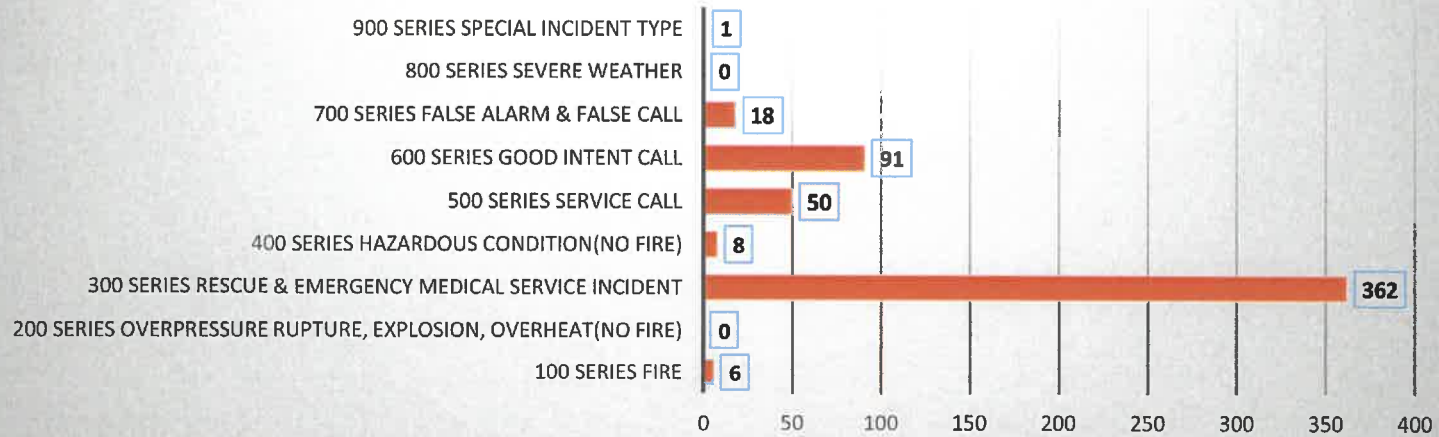



Station Staffing

Payroll figures as of 1/8/2018

	Average Salary	Taxes/WC/Retirement/ Insurance (58%)	Total Salary
Firefighter	54,227.92	31,452.19	85,680.11
Driver Engineer	67,497.38	39,148.48	106,645.86
Lieutenant	83,231.52	48,274.28	131,505.80
Captains	102,670.00	59,548.60	162,218.60

96,162.99

**Squad Staffing 2 persons**

Lieutenant (3)	394,517.40
FF or DE (3)	288,488.96
Annual Compensation w/o Overtime	683,006.37



**GREATER NAPLES FIRE RESCUE DISTRICT  
BOARD OF FIRE COMMISSIONERS  
Agenda Item**

**NEW BUSINESS**

**Agenda Item:** III. B.  
**Subject:** Ochopee Management Agreement  
**Meeting Date:** February 13, 2018  
Commissioner Gerrity

---

**INTERLOCAL AGREEMENT FOR FIRE AND RESCUE SERVICES  
BY AND BETWEEN  
COLLIER COUNTY AND GREATER NAPLES FIRE RESCUE DISTRICT**

This Interlocal Agreement, made and entered into this 13<sup>th</sup> day of **September**, 2016, by and between the Board of County Commissioners of Collier County, Florida, a political subdivision of the State of Florida (hereinafter referred to as the "County"), and the Greater Naples Fire Rescue District, an Independent Special District created under Chapter 2014-240, Laws of Florida, and operated pursuant to Chapter 191, Florida Statutes (hereinafter referred to as "Greater Naples").

**RECITALS:**

WHEREAS, by Ordinance No. 78-49, as subsequently amended, the County created the Ochopee Municipal Fire Services Taxing District (hereinafter referred to as the "Ochopee Fire Control District"), "for the purpose of providing, equipping, operating, and maintaining a rescue and fire department within the district; to buy, lease, sell, exchange or otherwise acquire, hold and dispose of equipment and other personal or real property and to provide an adequate water supply for fire prevention and protection purposes; to employ and discharge employees and authorize them to enter upon private and public property at reasonable times to inspect, combat and investigate possible and actual fire hazards and occurrences; to promulgate rules and regulations for the prevention and control of fire and to otherwise protect persons and property within the district;" and

WHEREAS, the parties intend to consolidate the Ochopee Fire Control District into Greater Naples, which would ultimately require appropriate action by the Florida Legislature and approval at referendum of the qualified electors within the Ochopee Fire Control District; and

WHEREAS, as an interim measure, until action can be taken by the Florida Legislature, the County would like Greater Naples to manage the Ochopee Fire Control District including its fire station ("Fire Stations 60, 61, 63, and 66") on behalf of its governing body, the Board of County Commissioners, which Greater Naples is willing to do, pursuant to and in accordance with the terms of this Interlocal Agreement; and

WHEREAS, the Interlocal Cooperation Act of 1969 set forth in Chapter 163, Florida Statutes, authorizes the joint exercise of any power, privilege or authority which the public agencies involved might separately exercise.

**WITNESSETH:**

NOW, THEREFORE, in accordance with the mutual covenants contained herein, the parties agree as follows:

1. **TERM OF AGREEMENT:** This Agreement shall commence on November 1, 2016, and will terminate on September 30, 2019, subject to the early termination provision provided

below in numbered paragraph 14, during which time Greater Naples will initiate legislative action to annex the Ochopee Fire District.

**2. TERMS OF PAYMENT:** The County will set the annual millage rate for the Ochopee Fire Control District at 4.5 mills for the first and second year of this agreement. The third year under the agreement, assuming the loan to Collier County is paid in full, the millage rate will be reduced to 4.0 mills, if the loan to Collier County is not paid in full, the millage will remain at 4.5 mills. The County will pay Greater Naples in monthly installments the amount that is collected from this MSTU net of costs required to be paid to the property appraiser, tax collector as well as any other associated fees and costs.

Prior to the receipt of ad valorem property tax revenue, which generally does not post until late November, the County will pay to Greater Naples on or about October 1st, a sum equal to two twelve's (2/12) of 95% of ad valorem proceeds budgeted (for example; based upon the July 2016 tentative budget totals the payment would be approximately \$233,500). Thereafter monthly beginning with the December posting, the County will pay to Greater Naples the exact amount of ad valorem proceeds posted until the last monthly posting (generally in June or July). In August, after the last ad valorem tax receipt is posted, the County will pay to Greater Naples a true up amount which is defined as the total amount of ad valorem proceeds posted to the County's accounting system less the amount paid. In no instance will the amount of ad valorem proceeds paid to Greater Naples exceed the amount of ad valorem revenue posted in the County's accounting system.

Collier County will pay in the first quarter of the fiscal year to Greater Naples for the length of the agreement the revenue amount budgeted as "Transfer from 001 General Fund" consistent with the FY17 approved budget figure in the amount of \$565,100.

At year end, other eligible, appropriate and legally available non ad valorem revenue posted to the accounting system such as Impact fees, Inspection fees, and Excess fees returned from the property appraise and tax collector, etc., will be paid to greater Naples with the explicit understanding that the year ending case balance will not drop below 110% of the amount needed to fund the next year's initial payment installment which is due on or about October 1<sup>st</sup>. In the event of an approved and authorized full annexation, the audited financial reserves, if any, shall be remitted to Greater Naples.

**FDOT Station 63 Funding:** Collier County will, in accordance with Section 14H of the Interlocal Agreement with Florida Department of Transportation (FDOT), assign the funding agreement to Greater Naples. Greater Naples will be responsible for complying with and monitoring the terms and conditions of the current contract with FDOT for funding.

Collier County and Greater Naples will work cooperatively with FDOT to establish permanent funding for said station. Specifically, no later than October 1, 2017, Greater Naples, working with County staff, will draft and present to the Collier County State legislative delegation, a proposed bill or other legislative remedy to secure permanent state funding for the MM63 public safety station and lobby the Legislature for approval.

**3. SERVICE LEVEL:** Greater Naples will provide the Ochopee Fire Control District with the current level of fire protection and rescue services that Ochopee Fire Control District provides its residents. Greater Naples strives to meet a standard of three personnel per station. All

decisions on staffing and equipment will be made by Greater Naples. Fire protection and rescue services provided by Greater Naples will include all emergency and non-emergency services normally performed by Greater Naples, including all those services required by law. This Agreement does not alter any Mutual Aid or other agreement between the parties. Service levels will include, at a minimum, the following:

- Up to of three firefighters, but a minimum of two (1 lieutenant, 1 driver/engineer, 1 firefighter) assigned to one (1) Class-A fire apparatus, 24 hours each day stationed at Isles of Capri Fire Station, which station shall at all times remain open, operational, and fully staffed with no "brown out" shifts
- Marine capability as currently provided
- Fire prevention and investigative services
- Fire inspections and new occupancy inspections
- On-duty Shift Commander available at all times
- Reserve fire engine available when necessary
- Other apparatus (brush attack, air trucks and squads) available as needed
- Preparation and coordination of emergency preparedness activities

**4. ADMINISTRATION AND RECORDS MANAGEMENT:** Greater Naples will provide all required administrative and support services, and will provide statistical and data analysis to the County upon request. Greater Naples will be responsible for all personnel administration, which includes at a minimum, hiring, promotions, disciplinary action up to and including termination, planning, organizing, directing, and coordinating the work of all personnel, and developing and implementing training programs.

**5. PUBLIC RELATIONS AND OTHER SERVICES:** The Greater Naples Fire Chief or designee will prepare the agenda for and attend Ochopee Fire Advisory Committee meetings; will liaison with outside agencies, the media and the public; when requested will provide activity reports to the County Manager; and will provide any information requested by the Board of County Commissioners.

**6. PERSONNEL:** All services provided under this Agreement will be under the supervision of Greater Naples and will be performed by employees of Greater Naples. Prior to the effective date of this agreement, Greater Naples will initiate the hiring process to ensure current Ochopee Fire Control District employees are processed so as to begin employment with Greater Naples upon the effective date of this agreement. Upon the effective date of the agreement, all permanent Union employees of Ochopee Fire Control District will be transferred to Greater Naples in accordance with Local 2396 Collective Bargaining Agreement (CBA). Non bargaining employees will be covered by the GNFD Employee Handbook. The terms of employment and accrued vacation leave balance and up to 144 hours of accrued sick leave shall be carried over. There will be no negative impact on their compensation, assignment or position, longevity and seniority. Should this agreement terminate without a consolidation with or annexation into the Greater Naples Fire District, the County will re-hire these same employees under the same conditions:

- a. Assuming those employees have been continuously employed by Greater Naples since the effective date of this agreement;

- b. That there have been no adverse personnel events that would prevent rehire by the County; and
- c. Subject to any rights under existing collective bargaining agreements at the time of rehire.

For the first year of this agreement, to assist with continuity and a smooth transition, Greater Naples will endeavor to retain current Ochopee Fire Control District staff at the Ochopee Fire Stations subject to operational needs of the District.

**7. OWNERSHIP OF VEHICLES, FACILITIES AND EQUIPMENT:** An inventory and inspection of all supplies, vehicles and equipment located within the Ochopee Fire Stations or otherwise owned by the district will be jointly conducted prior to the effective date of this agreement and a report of same compiled and accepted by both parties. It is expressly understood and agreed by the Parties that the title to these supplies, vehicles and equipment will remain the property of the County, and the Greater Naples agrees not to lease, loan, sell, sublet, assign or mortgage any item on this Inventory Report, or the Fire Station itself, without the County's prior written consent. In the event of an approved and authorized full annexation, the equipment, inventory and all assets listed in the Exhibit attached hereto shall become the property of Greater Naples. All existing supplies and equipment are to be used to perform the services included herein and must remain accountable within the Greater Naples and Ochopee Fire Districts unless being maintained or repaired. In addition:

a) The County reserves the right to station a Collier County EMS ambulance and personnel and equipment at the Ochopee Fire Station at the current budgeted rate.

b) The County shall conduct a biennial physical inspection, to commence from the effective date of this Agreement, to ensure that vehicles, facilities, and equipment are properly maintained in accordance with the requirements of this Agreement. The County shall provide Greater Naples with 72-hour notice of a planned inspection.

c) For any non-routine, single Capital expense exceeding \$5,000 related to the equipment, vehicles, and inventory items referenced in paragraphs 7 and 10, Greater Naples may request financial assistance from the County.

**8. VEHICLE MAINTENANCE:** Greater Naples shall repair and maintain at its sole cost and expense all vehicles identified in the Inventory Report in first-class condition and repair in accordance with the vehicle manufacturer's warranty and maintenance guidelines, Florida Administrative Code Chapter 14-90 Safety Rules, as amended, and all NFPA required testing, maintenance, practices and procedures. Greater Naples shall maintain a complete and accurate record with respect to vehicle maintenance and repairs and shall forward a copy of this record to the County Manager on request.

**9. RETURN OF VEHICLE:** If termination of this Agreement occurs prior to the full consolidation of the Ochopee Fire District, Greater Naples shall return all vehicles identified in the Inventory Report to the County in the same condition in which they were received by Greater Naples, ordinary wear and tear and natural depreciation excepted. Tires shall be in good condition with a minimum average of no less than 7/32" tread remaining.

**10. EQUIPMENT AND FACILITIES MAINTENANCE:** Greater Naples will maintain all equipment, grounds and facilities (including, if applicable, the boat and boat dock) in the condition in which it was received at the time this Agreement becomes effective less normal wear and tear. Greater Naples will assume all cost for utilities, telephone service, cable and internet service.

**11. INSURANCE:** Greater Naples shall at its own expense, carry and maintain insurance coverage through the County or from responsible companies duly authorized to do business in the State of Florida as follows:

a) Workers' Compensation limits shall be on a statutory basis in accordance with Florida Statutes, Chapter 440. Workers' Compensation coverage shall be extended to include coverage for claims under the United States Longshoreman and Harbor Workers Act. Policy must include Employers Liability coverage with a limit of not less than \$1,000,000 each accident.

b) Commercial General Liability - Bodily Injury and Property Damage - \$1,000,000 per occurrence. Personal Injury - \$1,000,000 per occurrence; Products/Completed Operations Annual Aggregate - \$2,000,000; General Aggregate for all claims - \$2,000,000.

c) Automobile Liability and Physical Damage - Combined Single Limit \$1,000,000 per occurrence for bodily injury and property damage. Comprehensive and Collision coverage shall be maintained on all vehicles. Vehicles valued over \$50,000 shall be insured on an agreed value.

e) Maritime Employer's Liability/Watercraft Liability including Protection and Indemnity and Hull Insurance - Coverage shall be purchased on watercraft. Maritime Employer's Liability in an amount of not less than \$1,000,000 per occurrence including coverage for captain and crew members. Hull Insurance shall be purchased to cover damage to the vessel(s) on a full replacement cost basis.

f) Property Insurance - Coverage shall be maintained on real and personal property incorporated as part of this agreement. The property insurance obtained by Greater Naples shall, at a minimum, insure against perils on an All Risks of Loss basis. Valuation shall be on a replacement cost basis.

g) Flood Insurance - Flood insurance shall be maintained on real and personal property incorporated as part of this agreement. Limits shall be purchased for the full value of said property.

h) The Collier County Board of Commissioners shall be named as the Certificate Holder.

i) The Collier County Board of Commissioners shall be named as additional insured on the Greater Naples Commercial General Liability Policy.

j) The Collier County Board of Commissioners shall be named as a Loss Payee on the Automobile Physical Damage and Property Insurance policies.

k) The amounts and types of insurance coverage shall conform to the following minimum requirements with the use of Insurance Services Office (ISO) forms and endorsements or their

equivalents. If Greater Naples has any self-insured retentions or deductibles under any of the required coverage, Greater Naples must identify on the Certificate of Insurance the nature and amount of such self-insured retentions or deductibles and provide satisfactory evidence of financial responsibility for such obligations. All self-insured retentions or deductibles will be Greater Naples's sole responsibility.

l) Coverage shall be maintained without interruption from the date of commencement of the Agreement until the date of completion or as specified in this Agreement, whichever is longer. Should at any time Greater Naples not maintain the insurance coverage required herein, the County may terminate the Agreement or at its sole discretion shall be authorized to purchase such coverage and charge Greater Naples for coverage purchased. If Greater Naples fails to reimburse the County for such costs within thirty (30) days after demand, the County has the right to offset these costs from any amount due Greater Naples under this Agreement.

m) Greater Naples and/or its insurance carrier(s) shall provide 45 days written notice to the County of any policy cancellation or non-renewal on the part of the insurance carrier or Greater Naples. Greater Naples shall also notify the County, in a like manner, within twenty-four (24) hours after receipt, of any notices of expiration, cancellation, non-renewal or material change in coverages or limits received by Greater Naples from its insurer and nothing contained herein shall relieve Greater Naples of this requirement to provide notice. In the event of a reduction in the aggregate limit of any policy to be provided by Greater Naples hereunder, Greater Naples shall immediately take steps to have the aggregate limit reinstated to the full extent permitted under such policy. If the initial or any subsequently issued Certificate of Insurance expires prior to the completion of the Work or termination of this Agreement, Greater Naples shall furnish to the County, renewal or replacement Certificate(s) of Insurance not later than ten (10) calendar days after to the date of their expiration. Failure of Greater Naples to provide the County with such renewal certificate(s) shall be considered justification for the County to terminate this Agreement.

n) To the extent permitted by law and as limited by and pursuant to the provisions of *Florida Statutes, Section 768.28* Greater Naples and County agree to hold harmless the other, employees and agents against any and all claims and/or damages by or behalf of any persons, employee or legal entity arising from their respective negligent acts pursuant to this agreement that allows employees of the other to occupy and ride in each other's vehicles. Nothing is intended to alter either party's immunity in tort or otherwise impose liability on Greater Naples or the County when it would not otherwise be responsible.

o) Greater Naples shall make available to the County, through its records or the records of their insurer, information regarding a specific claim. Any loss run information available from Greater Naples or their insurer will be made available to the County upon its request.

**12. COOPERATION WITH PUBLIC UTILITIES.** Greater Naples will cooperate with Port of the Islands CID and Everglade City. GNFD shall not assume ownership of any existing fire hydrants.

**13. RESOLUTION OF CONFLICTS:** The County Manager and the Greater Naples Fire Chief will amicably attempt to resolve any conflicts that arise out of this Agreement. For any



item that cannot be amicably resolved, the issue will be brought to the Board of County Commissioners for a duly noticed public hearing. Should the matter not be resolved to both party's satisfaction, then unless the parties agree to a different form of dispute resolution, either party may file an action in the Circuit Court of Collier County to enforce the terms of this Agreement, said remedy being cumulative with any and all other remedies available to the parties for the enforcement of this Agreement.

**14. TERMINATION OF AGREEMENT:** This Agreement is intended to be an interim relationship pending the successful consolidation of the Ochopee Fire Control District into Greater Naples. Until the local legislative delegation accepts a consolidation bill to be presented to the legislature, either party may freely terminate this Agreement on 90 day's written notice to the other. Following receipt of such notice, the parties will cooperate with one another to ensure an orderly transition of the Ochopee Fire Control District back to County control and management, and Greater Naples will continue to operate the Ochopee Fire Control District under the terms of this Agreement until a final turnover date is set by the Board of County Commissioners. Payment to Greater Naples for this period shall be based on the monthly prorated amount that would otherwise be due under paragraph 2 above. Should the County wish to terminate this agreement for any reason other than failure to achieve approval of the electors after that time, the County will reimburse Greater Naples for any outside legal expense associated with the preparation of the consolidation bill.

#### **Standard Form Legal Provisions**

15. In the event state or federal laws are enacted after the execution of this Agreement, which are applicable to and preclude in whole or in part the parties' compliance with the terms of this Agreement, then in such event this Agreement shall be modified or revoked as is necessary to comply with such laws, in a manner which best reflects the intent of this Agreement.

16. This is the entire agreement between the parties with respect to the matters set forth herein, and any prior agreements or understandings of any kind are hereby merged and integrated herein. This Agreement can only be amended by mutual written consent of the parties. All notices and other communications required or permitted hereunder shall be in writing and shall be sent by Certified Mail, return receipt requested, or by a nationally recognized overnight delivery service, and addressed as follows:

As to County: County Manager  
Harmon Turner Building  
3299 East Tamiami Trail, Suite 200  
Naples, Florida 34112

With copy to: County Attorney  
Harmon Turner Building  
3299 East Tamiami Trail, Suite 800  
Naples, FL 34112

As to Greater Naples: Greater Naples Fire Commission Chairman  
Greater Naples Fire Rescue  
14575 Collier Blvd.  
Naples, Florida 34119

With copy to: Fire Chief  
Greater Naples Fire Rescue  
14575 Collier Blvd.  
Naples, Florida 34119

Notice shall be deemed to have been given on the next successive business day to the date of the courier waybill if sent by nationally recognized overnight delivery service.

17. This Agreement shall be recorded by the County in the Official Records of Collier County, Florida, within fourteen (14) days after the County enters into this Agreement. The County shall provide a copy of the recorded document to Greater Naples.

IN WITNESS WHEREOF, the parties hereto have caused this Interlocal Agreement to be executed by their appropriate officials, as of the date first above written.

ATTEST:  
 DWIGHT E. BROCK, Clerk

BOARD OF COUNTY COMMISSIONERS  
 COLLIER COUNTY, FLORIDA

By: \_\_\_\_\_  
 , Deputy Clerk

By: Donna Fiala  
 Donna Fiala  
 CHAIR

WITNESSES:

GREATER NAPLES FIRE  
 RESCUE DISTRICT

Wayne J. Martin  
 Signature  
Wayne J. Martin  
 Printed Name

By: Jeff Page  
 Jeff Page, CHAIR

Suanne Woeste  
 Signature  
SUANNE WOESTE  
 Printed Name

Approved as to form and legality:

[Signature]  
 Jeffrey A. Klatzkow  
 County Attorney

REVENUE	Budgeted	Current
Ad Valorum	1,440,341.00	621,824.58
Management fee	565,100.00	565,100.00
Inspection Fee	3,000.00	1,153.00
Hurricane reimbursment	0.00	103,628.29
	2,008,441.00	1,291,705.87

EXPENSE		
Payroll/benefits	1,586,242.00	528,747.33
Contractual services	19,605.00	10,973.00
Communications	20,000.00	8,201.00
Utlility	12,750.00	3,259.00
General Insurance	5,000.00	5,000.00
repair and maintnenance	11,500.00	61,824.00
vehicle repairs	30,000.00	10,650.00
Marine repairs	6,000.00	0.00
Fuel	8,500.00	2,833.33
operating supplies	3,500.00	1,527.00
Small Equipment	12,000.00	2,564.00
	1,715,097.00	635,578.67

			OCHOPEE FY 2017-2018	
COLLECTED AMT.	COLLECTION FEES	DISBURSED		DESCRIPTION
0.00	0.00	227,097.50		Sum equal to 2/12 of 95% of ad valorem proceeds budgeted based upon the July 2017 tentative budget totals.
402,782.73	8,055.65	394,727.08		December payment - Ad Valorem
<b>402,782.73</b>	<b>8,055.65</b>	<b>621,824.58</b>	<b>Sub-Total</b>	
0.00	0.00	565,100.00		Fire Mang. Agreement - 1st Qtr. Fiscal year
		1,186,924.58		

			OCHOPEE FY 2016-2017	
COLLECTED AMT.	COLLECTION FEES	DISBURSED		DESCRIPTION
0.00	0.00	233,478.00		Sum equal to 2/12 of 95% of ad valorem proceeds budgeted based upon the July 2016 tentative budget totals.
10,392.73	311.78	10,080.95		October payment
165,201.47	4,956.04	160,245.43		11/15/16 payment
344,885.17	7,391.76	337,493.41		11/28/16 payment
548,552.00	10,971.04	537,580.96		December payment
66,039.92	1,320.80	64,719.12		January payment
39,020.00	780.40	38,239.60		February payment
82,671.93	1,653.44	81,026.60		March payment (paid \$8.11 too much / transposed numbers)
93,009.69	1,860.19	91,149.50		April payment
14,746.80	294.94	14,451.86		May payment
14,746.80	294.94	14,451.86		June payment
47,642.83	952.86	46,689.97		Tax Certificate Sale
226.18	4.52	221.66		Tax Certificate Sale
		-233,478.00		Less 1st payment
<b>1,427,135.52</b>	<b>30,792.71</b>	<b>1,396,350.92</b>	<b>Sub-Total</b>	
3.32	0.00	3.32		Prior Certificate - January payment
350.07	0.00	350.07		Warrants - January payment
61.39	0.00	61.39		Ad Valorem Interest - January payment
74.64	0.00	74.64		Prior Certificate - April payment
22.25	0.00	22.25		Ad Valorem Interest - April payment
62.94	0.00	62.94		Current Certificate - July
10,070.95	0.00	10,070.95		Prior Certificate - July payment
20.64	0.00	20.64		Warrants - August
5,780.99	0.00	5,780.99		Prior Certificate - August
1,360.70	0.00	1,360.70		Certificate-Current
19.35	0.00	19.35		Ad Valorem Interest - August
<b>1,427,550.30</b>	<b>30,792.71</b>	<b>1,414,178.16</b>	<b>TOTAL</b>	
		565,100.00		Management Fee
		1,979,278.16		



**Florida Department of Transportation**

RICK SCOTT  
GOVERNOR

605 Suwannee Street  
Tallahassee, FL 32399-0450

RACHEL D. CONE  
INTERIM SECRETARY

May 11, 2017

Mr. Brian Telfair  
Realty Officer  
Federal Highway Administration  
3500 Financial Plaza, Suite 400  
Tallahassee, FL 32312

RE: Request for FHWA Concurrence Request

File Name: Mile Marker 63 Rest Area (the Fire Station)

Dear Mr. Telfair:

Attached for your review is a request for an updated FHWA concurrence of the Mile Marker 63 Rest Area (the Fire Station). A Joint Resolution was approved by the Collier County Board of County Commissioners and the Greater Naples Fire District approving the assignment of the Mile Marker 63 funding/airspace agreement from the County and DOT to Greater Naples and FDOT.

Included in this package are the Joint Resolution, Partial Assignment and Amendment of the Interlocal Agreement Between the Florida Department of Transportation and Collier County, Exhibits, and previously executed Airspace Agreement.

Please communicate your response directly to this office. If you have any additional questions, please contact me or Laurie Pizzo, State Property Management Administrator, at (850) 414-4609.

Sincerely,

A. J. Jim Spalla  
Director, Office of Right of Way

AJS/lp  
Attachments

APPROVED:

DATE:

5/11/17

For the Division Administrator

**PARTIAL ASSIGNMENT AND AMENDMENT OF  
THE INTERLOCAL AGREEMENT  
BETWEEN  
THE FLORIDA DEPARTMENT OF TRANSPORTATION  
AND COLLIER COUNTY**

**THIS PARTIAL ASSIGNMENT AND AMENDMENT** (the "Assignment") is between THE STATE OF FLORIDA, DEPARTMENT OF TRANSPORTATION (the "Department"), COLLIER COUNTY (the "County" or "Assignor"), and GREATER NAPLES FIRE RESCUE DISTRICT, an Independent Special District created under Chapter 2014-240, Laws of Florida ("Greater Naples" or "Assignee") (the Department, County, and Greater Naples are each, a "Party" and collectively, the "Parties"). This Assignment is effective on the date last signed.

**RECITALS**

WHEREAS, Pursuant to Section 163.01, Florida Statutes, and Section 338.26(3), Florida Statutes, the Department and County previously entered into an Agreement dated May 9, 2014 (the "Agreement") to develop and operate a fire station at the Department's Mile Marker 63 Rest Area ("the Fire Station") on Alligator Alley in Collier County, Florida; and

WHEREAS, the County and Greater Naples intend to consolidate the Ochopee Fire Control District into Greater Naples but this will require future action by the Florida Legislature and approval at referendum of the qualified electors within the Ochopee Fire Control District; and

WHEREAS, as an interim measure, until action can be taken by the Florida Legislature, the County desires for Greater Naples to assume the County's responsibility for management of the Ochopee Fire Control District, including its fire station located at Mile Marker 63 that is funded through the Interlocal Agreement, pursuant to and in accordance with the Agreement; and

WHEREAS, the County and Greater Naples entered into an Interlocal Agreement for Fire and Rescue Services, dated September 13, 2016, the County agreed to assign the Agreement with the Department that provides funding for the station located at Mile Marker 63, pursuant to Section 14.H, of the Agreement; and

WHEREAS, the Parties have agreed to partially assign the Agreement from Assignor to Assignee, and also to modify the Agreement by this Assignment.

NOW, THEREFORE, in consideration of the mutual covenants of this Assignment, the Parties agree as follows:

**AGREEMENT**

1. **Recitals.** The recitals set forth above are true and correct and are hereby incorporated into this Agreement in their entirety.
2. **Assignment:**

- a. Assignor grants, bargains, sells, conveys, transfers, assigns, and sets over its entire right, title, interest in and duties under the Agreement as amended, but excluding Assignor's duties under Section 8.D. and 8.F. of the Agreement as amended regarding repayment of the advance payment and interest to the Department, and including but not limited to the Airspace Agreement attached to the Agreement as Exhibit A, to Assignee subject to the covenants and conditions set forth in this Assignment.
- b. Assignee assumes all obligations of Assignor under the Agreement for all work undertaken by Assignor prior to the effective date of this Assignment, and Assignee assumes the Agreement and will perform faithfully all of the covenants, stipulations, and agreements contained in the Agreement. However, notwithstanding the foregoing, Assignor's retains its duties under Section 8.D. and 8.F. of the Agreement as amended regarding repayment of the advance payment and interest to the Department.
- c. Within thirty (30) days of execution of this Assignment, the Assignor shall return to the Department all funds advanced by the Department to Assignor under the Agreement and any interest earned on such advanced funds.
- d. The Department consents to the partial assignment of the Agreement to Assignee.
- e. Assignor represents, and Assignee accepts, that there are no claims or demands against the Department arising out of or related to the performance under the Agreement prior to the effective date hereof.

3. Amendment: The Agreement is modified as follows:

- a. All references to "County" or "the County" in the Agreement, except as set forth in Amendment 3.b. and 3.c below, are deleted and replaced with "Greater Naples".
- b. Section 8.D is deleted and replaced with the following:

D. All funds advanced by the DEPARTMENT shall be separated by the County from all other funds; and all funds advanced and all interest earned on such advanced funds shall be returned to the DEPARTMENT by the County within thirty (30) days of execution of the Partial Assignment of the Agreement from the County to Greater Naples.

- c. Section 8.F. is deleted and replaced with the following:

F. In the initial year of the Term and during the subsequent years of the Term and subject to the terms of this Agreement, the DEPARTMENT will fund Greater Naples for its direct actual costs of operating the fire station an amount each year not to exceed \$1,498,100.00, as outlined in Exhibit "B" and as adjusted for CPI as outlined in paragraph C above. Greater Naples will invoice on a monthly basis

direct actual costs incurred. The County shall return all funds advanced and interest earned to the DEPARTMENT within thirty (30) days of execution of the Partial Assignment of the Agreement from the County to Greater Naples.

- d. Section 14.I is amended to delete the name and address for the County and replace it with the following:

**Greater Naples Fire Rescue District  
Greater Naples Fire Rescue  
14575 Collier Blvd.  
Naples, Florida 34119**

- e. Exhibit "E", Joint Resolution of the Board of Commissioners of Collier County and the Greater Naples Fire Rescue District authorizing the County and Greater Naples to enter this Assignment, is attached to this Assignment and incorporated into the Agreement as Exhibit "E".
- f. Unless as otherwise amended by this Assignment, all terms and conditions of the Agreement shall remain.

4. Counterparts: Email Signatures. This Assignment may be executed in any number of counterparts, each of which shall be considered an original, and all of such counterparts shall constitute one amendment. To facilitate execution of this Assignment, Department, County, and Greater Naples may execute and exchange by e-mail as a portable document format or other electronic imaging, counterparts of the signature page, which shall be deemed original signatures for all purposes.

[Signature Page Follows]



The Parties have executed this Assignment on the dates below.

COUNTY - (Assignor)

DEPARTMENT

The Board of Commissioners of Collier  
County, Florida

STATE OF FLORIDA,  
DEPARTMENT OF TRANSPORTATION

By: *Penny Taylor*  
Name: Penny Taylor  
Title: Chairman

By: *L.K. Nandam*  
Name: L.K. Nandam, P.E.  
Title: District Secretary

Date executed by Department:  
June 20, 2017

Date executed:  
May 23, 2017

Legal Review: *[Signature]*

ATTEST  
Dwight E. Brock, Clerk

By: *[Signature]*  
Attest as to Chairman's  
signature only as to Form and Legality:  
*[Signature]*  
Scott R. Teach, Deputy County Attorney

GREATER NAPLES - (Assignee)

Greater Naples Fire Rescue District

By: *Jeff Page*  
Name: Jeff Page  
Title: CHAIRMAN

Date executed:  
5/9/17, 2017



**AMENDED EXHIBIT B – Schedule of Capital and Annual Funding Schedule  
For SFY 2017/18**

<b>Item/Work Action/Milestone</b>	<b>Estimated Budgeted Amount Capital and O&amp;M</b>	
	<b>Estimated Budget Current</b>	<b>Estimated Budget Proposed 2017/18</b>
<b>Annual 3.5 Paramedics Hired (includes uniforms and protective clothing) Includes all benefits and all insurance coverage for personnel including workers compensation &amp; malpractice insurance</b>	<b>\$406,000</b>	<b>\$412,000</b>
<b>Annual 9.5 Fire Fighters Hired – Uniforms/Gear noted below. Includes all benefits and all insurance Coverage for personnel including workers Compensation. This includes Administrative Assistant support &amp; 1/3 of Battalion Chief's salary and benefits</b>	<b>\$844,000</b>	<b>\$850,000</b>
<b>Annual Admin/Indirect costs/800 MHZ maintenance/IT services/phone/Internet/radio repair, maintenance, parts and accessories</b>	<b>\$27,000</b>	<b>\$27,000</b>
<b>Annual Building maintenance</b>	<b>\$7,000</b>	<b>\$7,000</b>
<b>Annual Bulk fuel on site- estimate includes Trucks, &amp; station generator fill and estimated Annual consumption. This also includes Diesel Exhaust Fluid.</b>	<b>\$25,000</b>	<b>\$25,000</b>

**Amended Exhibit "B" as per Contract Number: ARF81 Financial Project ID: 435289-1-94-01  
For SFY 2017/18 with CPI**

**Department-Greater Naples Fire Rescue District Inter local Agreement**

<b>Action/Milestone</b>	<b>Estimated Budget Current</b>	<b>Estimated Budget Proposed 2017/18</b>
<b>Annual Canal dive and water search &amp; Rescue Equipment, Haz/Mat absorbent &amp; Response, foam, minor medical, minor operating equipment</b>	<b>\$24,000</b>	<b>\$24,000</b>
<b>Annual Haz/Mat-Mutual Aid contingency</b>	<b>\$9,000</b>	<b>\$9,000</b>
<b>Annual Insurance- All Coverage Estimates for Facilities, errors and Omissions, portable equipment environmental estimated, vehicles</b>	<b>\$30,000</b>	<b>\$30,000</b>
<b>Annual Electric estimated (water and Sewer included in site lease provided by FDOT Rest Area systems)</b>	<b>\$10,000</b>	<b>\$10,000</b>
<b>Annual Vehicle and Apparatus, Small Equipment and Compressor maintenance repair, SCBA, Hose, Apparatus, Protective Clothing testing/certification and calibration</b>	<b>\$34,000</b>	<b>\$59,000</b>
<b>Annual Minor office supplies, Printers &amp; Display Monitors</b>	<b>\$3,500</b>	<b>\$3,500</b>
<b>Annual Minor station supplies</b>	<b>\$4,469.60</b>	<b>\$5,356.50</b>
<b>Annual Operational, Training &amp; Licensing</b>	<b>\$5,000</b>	<b>\$5,000</b>

**Amended Exhibit "B" as per Contract Number: ARF81 Financial Project ID: 435289-1-94-01 For SFY 2017/18 with CPI**

Department-Greater Naples Fire Rescue District Inter local Agreement

Action/Milestone	Estimated Budget Current	Estimated Budget Proposed 2017/18
Annual Uniform clothing, accessories, personal protective gear and safety equipment	\$12,000	\$15,000
Annual Machinery and Fire Equipment, Radio, Station Appliance and RO Water System Replacement	\$51,100	\$40,000
Annual EMS Medical Supplies, Equipment And Equipment Maintenance	\$30,000	\$20,000
<b>Annual O&amp;M for SFY With CPI Total</b>	<b>\$1,522,069.60</b>	<b>\$1,541,856.50</b>

**Amended Exhibit "B" as per Contract Number: ARF81 Financial Project ID: 435289-1-94-01  
For SFY 2017/18 with CPI.**

  
\_\_\_\_\_  
State of Florida Department of Transportation

Department-Greater Naples Fire Rescue District Inter local Agreement

This Amendment to Exhibit B of Contract Number: ARF81 Financial Project ID: 435289-1-94-01 for SFY 2017/18 with CPI is approved by the Greater Naples Fire Rescue District after motion, second, and majority vote favoring approval on May 9, 2017.

WITNESS:

GREATER NAPLES FIRE  
RESCUE DISTRICT

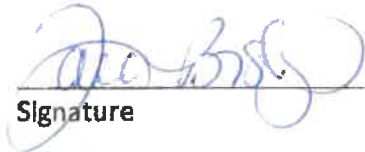
  
Signature

By:   
Jeff Paige, CHAIR

  
Printed Name

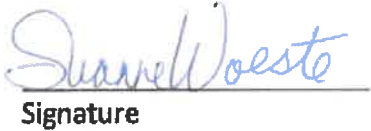
  
Signature

  
Printed Name

STATE OF FLORIDA)

COUNTY OF COLLIER)

I, DWIGHT E. BROCK, Clerk of Courts in and for the Twentieth Judicial Circuit, Collier County, Florida, do hereby certify that that the foregoing is a true and correct copy of:

**Joint Resolution 2017-25**

**Adopted by the BCC at the Meeting held on February 28, 2017**

**Agenda Item #16E11**

WITNESS my hand and the official seal of the Board of County Commissioners of Collier County, Florida, this 2nd day of March, 2017.

DWIGHT E. BROCK  
Clerk of Courts and Clerk  
Ex-officio to Board of  
County Commissioners



By: Martha Vergara  
Deputy Clerk

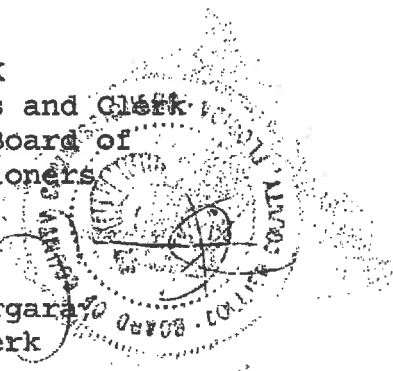

**JOINT RESOLUTION 2017 -25**

**JOINT RESOLUTION OF THE BOARD OF COMMISSIONERS OF COLLIER COUNTY, FLORIDA AND THE GREATER NAPLES FIRE RESCUE DISTRICT IN SUPPORT OF THE ASSIGNMENT OF AN INTERLOCAL AGREEMENT BETWEEN THE BOARD OF COUNTY COMMISSIONERS AND THE FLORIDA DEPARTMENT OF TRANSPORTATION CONCERNING THE FUNDING, EQUIPING AND PROVISION OF FIRE, RESCUE AND EMERGENCY SERVICES AT THE MILE MARKER 63 REST AREA ON ALLIGATOR ALLEY IN COLLIER COUNTY, FLORIDA (FINANCIAL MANAGEMENT No. 435389-1-94-01).**

**WHEREAS**, on May 9, 2014, the Board of Commissioners of Collier County, Florida ("County") entered into an Interlocal Agreement (along with an incorporated Airspace Agreement) with the Florida Department of Transportation that allowed for the lease of a fire station located at the mile marker 63 rest area on Alligator Alley in Collier County, Florida, to allow emergency vehicles to provide a faster emergency response time to the public (See the "FDOT Interlocal Agreement," attached hereto as Exhibit "A"); and

**WHEREAS**, the fire station leased to County was for the public purpose of operating a fire station that will include personnel and equipment capable of providing rescue and emergency medical services to motorists travelling on Alligator Alley (I-75); and

**WHEREAS**, the Interlocal Agreement set forth the terms, conditions and responsibilities of FDOT and County with respect to funding for the fire station, the respective duties of the parties to provide services at the mile marker 63 fire station and other such matters; and

**WHEREAS**, the County agreed to maintain the fire station and any encompassed structures or amenities in accordance with the terms and conditions of the Interlocal Agreement and the attached Airspace Agreement; and

**WHEREAS**, on September 13, 2016, the County and the Greater Naples Fire Rescue District (the "Greater Naples Fire District") entered into an Interlocal Agreement whereby the Greater Naples Fire District would manage the Ochopee Fire Control District, which includes the fire station located at mile marker 63, until action could be taken by the Florida Legislature that would annex and consolidate the Ochopee Fire Control District into the Greater Naples Fire District (See Exhibit "B," attached); and

**WHEREAS**, Section 2 of the September 13, 2016, Interlocal Agreement between County and the Greater Naples Fire District expressly provided for the assignment of the FDOT Interlocal Agreement from County to Greater Naples Fire District for all future responsibility of complying with the terms and conditions of the FDOT Interlocal Agreement; and

**WHEREAS**, the County and the Greater Naples Fire District agree that because Greater Naples Fire District is managing the personnel and assets at the mile marker 63 fire station that it is appropriate and in the public's best interest that the FDOT Interlocal Agreement be assigned to the Greater Naples Fire District.

**NOW, THEREFORE, BE IT RESOLVED BY THE BOARD OF COMMISSIONERS OF COLLIER COUNTY, FLORIDA AND THE GREATER NAPLES FIRE RESCUE DISTRICT THAT:**

1. Pursuant to that September 13, 2016, Interlocal Agreement, the Greater Naples Fire Rescue District is managing the personnel, assets and equipment located at the mile marker 63 fire station located on Alligator Alley in Collier County, Florida.
2. It is appropriate and in the public's best interest that the FDOT Interlocal Agreement be assigned to the Greater Naples Fire Rescue District for future responsibility and compliance with the terms and conditions of that agreement.
3. That Collier County and the Greater Naples Fire Rescue District request that the Florida Department of Transportation prepare an assignment agreement providing for the assignment of the FDOT Interlocal Agreement and incorporated Airspace Agreement from Collier County to the Greater Naples Fire Rescue District.

This Resolution was PASSED and DULY ADOPTED JOINTLY by the Board of Commissioners of Collier County, Florida and the Greater Naples Fire Rescue District on the below referenced dates.

ATTEST:  
DWIGHT E. BROCK, Clerk

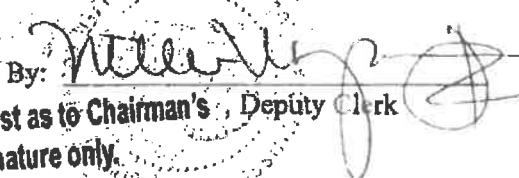
By:   
Attest as to Chairman's, Deputy Clerk  
signature only.

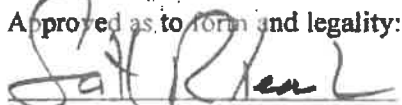
Approved as to form and legality:  
  
Scott R. Teach,  
Deputy County Attorney

BOARD OF COUNTY COMMISSIONERS  
OF COLLIER COUNTY, FLORIDA

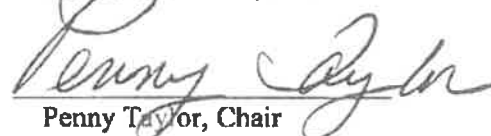
By:   
Penny Taylor, Chair

Dated: February 28, 2016

Attest:

By:   
Commissioner

GREATER NAPLES  
FIRE RESCUE DISTRICT

By:   
Jeff Pogo, Chair

Dated: 2/14/17







PLEASE REMIT PAYMENT TO:  
 GREATER NAPLES FIRE RESCUE DISTRICT  
 ATTN: ACCOUNTS PAYABLE  
 14575 COLLIER BLVD.  
 NAPLES, FL. 34119  
 INVOICE SUMMARY

CONTRACT NUMBER: ARF81 INVOICE DATE: 12-21-17 INVOICE: FDOT-1  
 FINANCIAL PROJECT ID: 435289-1-94-01 SERVICE PERIOD: 6-19-17 to 8-13-17

BUDGET ITEM	BUDGET CATEGORY	BILLED TO DATE	PREVIOUSLY BILLED	AMOUNT INVOICED
1	Annual 3.5 Paramedics Hired (includes uniforms & protective clothing) Includes all benefits and all insurance coverage for personnel including workers compensation & malpractice insurance			
2	Annual 9.5 Firefighters Hired – uniform/Gear noted below. Includes all benefits & all insurance coverage for personnel including workers compensation. This includes Administrative Assistant support & 1/3 of Battalion Chief's salary & benefits.			\$110,436.54
3	Annual Admin/Indirect/800mhz Maintenance/IT services/phone/Internet/radio repair, maintenance, parts & accessories			\$1,366.34
4	Annual Building Maintenance			\$119.00
5	Annual Bulk Fuel on-site-estimate includes trucks, & station generator fill & estimated annual consumption. This also includes Diesel Exhaust Fluid.			\$1,410.15
6	Annual Canal dive and water search & rescue equipment, hazmat absorbent & response, foam, minor medical, minor operating equipment,			
7	Annual Haz/Mat-Mut-Mut/Aid Contingency			
8	Annual Insurance-All Coverage Estimates for Facilities, errors and omissions, portable equipment environmental estimated, vehicles			
9	Annual Electric estimated (water & sewer included in site lease provided by FDOT Rest Area systems)			\$845.81
10	Annual Vehicle & Apparatus, Small Equipment & compressor maintenance Repair, SCBA, Hose, Apparatus, protective clothing/ testing/certification and calibration			\$125.13
11	Annual Minor Office Supplies, Printers & Display Monitors			\$120.00
12	Annual Minor Station Supplies			\$186.23
13	Annual Operational, Training & Licensing			
14	Annual Uniform Clothing, accessories, personal protective gear & safety equipment			\$5,133.40
15	Annual Machinery & Fire Equip, Radio, Station Appliance & Ro Water System replacement			\$995.60
16	Annual EMS Medical Supplies, Equipment & Equipment Maintenance			
	<b>TOTALS</b>	<b>0.00</b>	<b>0.00</b>	<b>\$120,738.20</b>

APPROVED BY:   
 NAME & TITLE



PLEASE REMIT PAYMENT TO:  
 GREATER NAPLES FIRE RESCUE DISTRICT  
 ATTN: ACCOUNTS PAYABLE  
 14575 COLLIER BLVD.  
 NAPLES, FL. 34119  
 INVOICE BY BUDGET CATEGORY

BUDGET ITEM 2,3,4,5,9,10,11,12,14,15

Contract Number: ARF81 Invoice Date: 12-21-17  
 Financial Project ID: 435289-1-94-01 Invoice Number: FDOT-1  
 Service Period: 6-19-17 to 8-13-17

ITEM/WORK	AMOUNT INVOICED	BUDGET ITEM CATEGORY
Payroll for 6-19-17 to 7-16-17(includes salary and benefits)	\$50,197.34	2
Payroll for 7-17-17 to 8-13-17(includes salary and benefits)	\$60,239.20	2
Century Link Qwest/Fiber Optic Serv Inv 1413466585 dated 6-27-17	\$550.00	3
Century Link Qwest /Fiber Optic Serv Inv 1416090637 dated 7-27-17	\$550.00	3
Century Link dated 7-14-17	\$157.95	3
Verizon 6-19-17 to 7-18-17 Inv 9789469201 (total costs for Rescue 63 cell service is \$37.67 for 30 days = \$1.25 per day 6-20-17 to 7-18-17 is 29 days x \$1.25 per day = \$36.25)	\$36.25	3
Verizon 6-24-17 to 7-23-17 air card service Inv 9789853314	\$72.14	3
Crystal Clear Water/RO System Serv Inv I120455 dated 6-28-17	\$79.00	4
ABC Fire Equipment/Hood Suppression Serv/Inv 71479 dated 7-13-17	\$40.00	4
Seminole Petroleum/clean on road diesel fuel	\$625.27	5
Seminole Petroleum/265.60 Gal Diesel Fuel/Inv 0610684 7-20-17	\$642.88	5
Seminole Petroleum/DEF Diesel Exhaust Fluid/Inv 0611214 8-10-17	\$142.00	5
LCEC/Electric Bill charges for FDOT from 6-20-17 to 7-2-17(total bill is \$557.26 divided by 30 days = \$18.57 per day x 13 days = \$241.41)	\$241.41	9
LCEC/Electric Bill for service from 7-3-17 to 8-2-17	\$604.40	9
Tamiami Ford/Inv FOCS548203 dated 7-18-17/repairs to Attack 63	\$125.13	10
Dell/printer for station 63/Inv 10179805049 dated 7-22-17	\$120.00	11
Lowe's/transaction# 76507433 dated 6-26-17/rolling utility cart	\$128.24	12
Northern Tool & Equip/Inv 6073063117 dated 8-9-17/commercial hose	\$57.99	12
MES/Bunker Gear for Fire Personnel/Inv IN1146521 dated 8-16-17	\$5,133.40	14
Lowe's/transaction# 2984408 dated 6-20-17/washing Machine	\$445.55	15
Lowe's/transaction# 2748664 dated 6-29-17/dryer	\$550.05	15
<b>TOTAL</b>	<b>120,738.20</b>	

Approved By:  Tara Bishop Deputy Director



PLEASE REMIT PAYMENT TO:  
 GREATER NAPLES FIRE RESCUE DISTRICT  
 ATTN: ACCOUNTS PAYABLE  
 14575 COLLIER BLVD.  
 NAPLES, FL. 34119  
 INVOICE SUMMARY

CONTRACT NUMBER: ARF81 INVOICE DATE: 1-22-18 INVOICE: FDOT-2  
 FINANCIAL PROJECT ID: 435289-1-94-01 SERVICE PERIOD: 8-14-17 to 10-8-17

BUDGET ITEM	BUDGET CATEGORY	BILLED TO DATE	PREVIOUSLY BILLED	AMOUNT INVOICED
1	Annual 3.5 Paramedics Hired (includes uniforms & protective clothing) Includes all benefits and all insurance coverage for personnel including workers compensation & malpractice insurance			
2	Annual 9.5 Firefighters Hired – uniform/Gear noted below. Includes all benefits & all insurance coverage for personnel including workers compensation. This includes Administrative Assistant support & 1/3 of Battalion Chief's salary & benefits.	\$246,375.62	\$110,436.54	\$135,939.08
3	Annual Admin/Indirect/800mhz Maintenance/IT services/phone/internet/radio repair, maintenance, parts & accessories	\$2,821.36	\$1,366.34	\$1,455.02
4	Annual Building Maintenance	\$3,003.35	\$119.00	\$2,884.35
5	Annual Bulk Fuel on-site-estimate Includes trucks, & station generator fill & estimated annual consumption. This also includes Diesel Exhaust Fluid.	\$3,562.04	\$1,410.15	\$2,151.89
6	Annual Canal dive and water search & rescue equipment, hazmat absorbent & response, foam, minor medical, minor operating equipment,			
7	Annual Haz/Mat-Mut-Mut/Aid Contingency			
8	Annual Insurance-All Coverage Estimates for Facilities, errors and omissions, portable equipment environmental estimated, vehicles			
9	Annual Electric estimated (water & sewer included in site lease provided by FDOT Rest Area systems)	\$1,840.64	\$845.81	\$994.83
10	Annual Vehicle & Apparatus, Small Equipment & compressor maintenance Repair, SCBA, Hose, Apparatus, protective clothing/ testing/certification and calibration	\$125.13	\$125.13	
11	Annual Minor Office Supplies, Printers & Display Monitors	\$120.00	\$120.00	
12	Annual Minor Station Supplies	\$196.21	\$186.23	\$9.98
13	Annual Operational, Training & Licensing			
14	Annual Uniform Clothing, accessories, personal protective gear & safety equipment	\$5,133.40	\$5,133.40	
15	Annual Machinery & Fire Equip, Radio, Station Appliance & Ro Water System replacement	\$995.60	\$995.60	
16	Annual EMS Medical Supplies, Equipment & Equipment Maintenance			
<b>TOTALS</b>		<b>264,173.35</b>	<b>120,738.20</b>	<b>\$143,435.15</b>

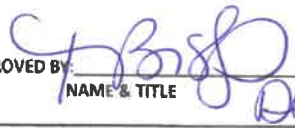
APPROVED BY:   
 NAME & TITLE: Deputy Director



PLEASE REMIT PAYMENT TO:  
 GREATER NAPLES FIRE RESCUE DISTRICT  
 ATTN: ACCOUNTS PAYABLE  
 14575 COLLIER BLVD.  
 NAPLES, FL. 34119  
**INVOICE BY BUDGET CATEGORY**

**BUDGET ITEM 2,3,4,5,9,12**

**Contract Number: ARF81      Invoice Date: 1-22-18**  
**Financial Project ID: 435289-1-94-01      Invoice Number: FDOT-2**  
**Service Period: 8-14-17 to 10-8-17**

ITEM/WORK	AMOUNT INVOICED	BUDGET ITEM CATEGORY
Payroll for 8-14-17 to 9-10-17(includes salary and benefits)	\$52,814.00	2
Payroll for 9-11-17 to 10-8-17(includes salary and benefits)	\$83,125.08	2
Century Link Qwest/Fiber Optic Serv Inv 1418702624 dated 8-27-17	\$550.00	3
Century Link Qwest /Fiber Optic Serv Inv 1421391524 dated 9-27-17	\$550.00	3
Century Link/Invoice dated 9-14-17 for phone service	\$173.19	3
Verizon/Rescue 63 cell phone/Inv 9791218736/Jul 19 - Aug 19	\$37.55	3
Verizon/cell phones & aircards Inv 9791600574/Jul 24 - Aug 23	\$144.28	3
Power Pro Tech/Inv OC01-041867/dated 8-15-17	\$910.91	4
Power Pro-Tech/Inv OC01-043736/dated 9-6-17	\$1,729.42	4
Crystal Clear Water/Serviced RO System/Inv I124893 dated 8-24-17	\$165.02	4
Crystal Clear Water/Serviced RO System/Inv I130816 dated 9-04-17	\$79.00	4
Seminole Petroleum/One Drum Dolly Inv 0611554 dated 8-23-17	\$120.57	5
Seminole Petroleum/230 gal diesel fuel Inv 0611941 dated 9-6-17	\$662.87	5
Combs Oil Company/diesel fuel Inv 100450 dated 9-21-17	\$1,368.45	5
LCEC/Electric Bill for 8-3-17 to 9-1-17	\$622.53	9
LCEC/Electric Bill for 9-2-17 to 10-1-17	\$372.30	9
Sams Club/Batteries for St 63	\$9.98	12
<b>TOTAL</b>	<b>143,435.15</b>	



**GREATER NAPLES FIRE RESCUE DISTRICT  
BOARD OF FIRE COMMISSIONERS  
Action Item Worksheet**

**NEW BUSINESS**

**Agenda Item:** III. C.  
**Subject:** Collier County LMS Mitigation Strategy  
**Meeting Date:** February 13, 2018  
**Prepared By:** Alan McLaughlin, Deputy Chief

**Background**

Collier County is threatened by a number of different types of natural, technological and societal or man-made hazards. These hazards endanger the health and safety of the people of the county, jeopardize its economic vitality, and imperil the quality of the natural environment. Because of the importance of avoiding or minimizing the County's vulnerability to these hazards, the public and private sector interests of Collier County joined together to undertake a comprehensive planning process and development of the Collier County Local Mitigation Strategy (LMS).

The LMS Working Group identifies the hazards threatening Collier County and to estimate the relative risks posed to the community by those hazards. With these identified, the Working Group identifies proposed projects and programs that will avoid or minimize these vulnerabilities to make the communities of Collier County more resistant to the impacts of future disasters.

The Collier County LMS Mitigation Strategy is funded, in part, by the Florida Department of Community Affairs with Federal Emergency Management Agency funds earmarked for the development of comprehensive mitigation planning.

The Public Safety Facility located in Naples Manor houses Fire Station 21, EMS, and the local Sheriff substation. At present the facility does not have a generator to supply emergency power to the site as a whole.

An application sheet has been submitted to the Local Mitigation group to determine eligibility for the mitigation grant to fund an emergency generator at the East Naples Public Safety building.

**Funding Source/Financial Impact**

The grant request is for \$110,000. If awarded \$27,500 would be funded from Greater Naples Fire FY18-19 Capital Projects and \$82,000 funded from grant.

**Recommendation**

Staff's recommendation is to proceed with eligibility process and apply for grant if deemed eligible.

**Potential Motion**

"I move to support Staff's recommendation to continue with the eligibility process and apply for the grant if eligible".

A handwritten signature in blue ink, appearing to read "Kevin O. Pace", written over a horizontal line.

**ANNEX I**  
**Initiative Scoring Criteria**

#### A. Mitigation Initiatives: Criteria for Scoring and Prioritizing

The prioritization of mitigation initiative process begins with the sponsor(s) of each initiative then goes to the Local Mitigation Strategy Working Group.

The first step consists of the sponsoring governments, agencies, and departments developing their initiatives, and then scoring each project using the matrix developed by the LMS Working Groups.

The sponsor's prioritized initiatives are then presented to the LMS Working Group, via the Collier County Emergency Management Department who will put the initiative on the LMS Agenda. The Working Group then reviews, discusses, revises, and votes on each of the initiatives, assigning each a score and a ranking using the scoring matrix. The list was then reviewed and revised by the Collier County Citizen Corps. Following further discussion, the decision was made that like initiatives should be scored alike and grouped. For this purpose, the scores derived from the matrix would be used as a guide to the grouping, and initiatives not grouped would retain their original scores derived from use of the matrix.

In grouping the initiatives, in addition to using the scores derived from the matrix as a guide, considerations such as useful life of the initiative, cost-effectiveness, funding capability, and time required to implement and complete the project were factored.

Upon the Citizen Corps approval of the revised Priority Listing, it will be updated in the Collier County Local Mitigation Strategy (Annex F).

B. Special Grant Funding Opportunities & other exigent circumstances: Should an eligible entity have an opportunity to apply for a mitigation grant for a project not previously listed on the Project Priority Listing (Annex F) and not be able to apply for the grant because the next announced LMSWG meeting would preclude timely application, this procedure applies. The applicant will complete a project score sheet, below, and submit it to the Emergency Management Department. Emergency Management will transmit the score sheet to the Chair. The Chair will electronically transmit the score sheet to the voting members of the LMSWG along with an explanation of the exigent circumstances. The LMSWG voting members have **two** business-days to vote on the project acceptability to the project priority listing. At the conclusion of the two business-days a majority vote, with at least three votes agreeing, determines the initiative's status. A transcript of this exception will be entered into the minutes at the next scheduled meeting.

#### C. Mitigation Initiatives Scoring Matrix

The following table represents the scoring matrix used for the submission of initiatives for consideration for inclusion in the Collier County LMS.

See Section 4, para. 4.1.4 for situations which deal with initiatives that cannot be scored.

**Mitigation Initiatives Evaluation Score Sheet**

**Instructions:** Applicant completes for EACH Project. Information required in each of the **SHADED AREAS**. Submit to Emergency Management Office electronically: [RichardZyvoloski@CollierGov.net](mailto:RichardZyvoloski@CollierGov.net) . Questions, call: 252-3600

If a submitter does not agree with the final determination he or she shall have the right to meet with the scoring committee to present compelling information to change the score.

**PART I**

Project Title:		<b>Greater Naples Fire and Rescue District Emergency Generator Replacement</b>					
Project Location:		<b>GNFR Fire Stations 21</b>					
<i>TYPE PROJECT ("X" appropriate box, or explain)</i>							
Acquisition	Elevation	Relocation	Reconstruction	Essential Facility	Non-Residential	New Construction	Special Considerations or Impact Statement, if any: The essential facilities requiring assistance serve and protect over 80 square miles (over 18,000 people to benefit) within a suburban/rural interface. Specifically, the rural interface, said fire stations are often the only place of community support during disaster and emergency situations. Fire Station #21 – The Emergency Generator POWERS that services Fire, EMS, and the CCSO.
							<b>XX</b>
What Goal or Objective does this address (See Sec. 3.0, LMS)?				Goal 3 Objective 3.2			
What hazard(s) does this project or initiative correct/mitigate?				State of Continual Ready Preparedness			
Who (what community) benefits from this project or initiative?				All of Collier County			
Does this project or initiative address mitigation on <b>NEW</b> infrastructure or buildings?							
Does this project or initiative address mitigation on <b>EXISTING</b> infrastructure or buildings?						<b>YES</b>	
Project or Initiative Description:		Replacement of outdated and damaged emergency generators at essential facilities.					
Applicant and Responsible Agency:		<b>Greater Naples Fire Control and Rescue District</b>					
<i>Agency Contact Information</i>							
NAME			E-Mail		PHONE		
Alan McLaughlin			amclaughlin@gnfire.org		239-285-3726		
Potential Funding Source(s) (See Annex J, LMS)		State Disaster Preparedness Grants		Estimated Cost	<b>\$110,000</b>		

Suitability			Score	For LMS WG only
1	Appropriateness of the Measure	<b>5- High:</b> Reduces vulnerability and is consistent with Local Mitigation goals and plans for future growth. <b>3- Medium:</b> Needed, but doesn't tie to identified vulnerability. <b>1- Low:</b> Inconsistent with LMS goal or plans.	5	
2	Community Acceptance	<b>5- High:</b> Endorsed by most communities. <b>3- Medium:</b> Endorsed by most; may create burdens. <b>1- Low:</b> Not likely to be endorsed by the communities.	5	
3	Environmental Impact	<b>5- Positive</b> effect on the environment. <b>3- No effect</b> <b>1- Adverse</b> effect on the environment.	3	
4	Legislation	<b>5- High:</b> Consistent with the existing laws and regulations. <b>3- Medium:</b> New legislation or policy change. <b>1- Low:</b> Conflicts with existing laws and regulations.	5	
5	Consistent With Existing Plans and Priorities.	<b>5- High:</b> Consistent with existing plans. <b>3- Medium:</b> Somewhat consistent. <b>1- Low:</b> Conflicts with existing plans and policies.	5	



Risk			Score	For LMS WG only
1	Scope of Benefits	<p><b>5- High:</b> Benefits all municipalities and unincorporated area directly or indirectly</p> <p><b>3- Medium:</b> Benefits more than half, but <b>not all of</b> not all of the municipalities and/or the unincorporated area.</p> <p><b>1-Low:</b> Benefits less than half of the municipalities and/or the unincorporated area.</p>	5	
2	Potential to save human lives	<p><b>5- High:</b> More than 1,000 lives</p> <p><b>3- Medium:</b> Up to 1,000 lives</p> <p><b>1- Low:</b> No lifesaving potential.</p>	5	
3	Importance of Benefits	<p><b>5- High:</b> Need for essential services.</p> <p><b>3- Medium:</b> Need for other services.</p> <p><b>1- Low:</b> No significant implications.</p>	5	
4	Inconvenience of Problem Correction	<p><b>5- None:</b> Causes no problems.</p> <p><b>3- Moderate:</b> Causes few problems.</p> <p><b>1- Significant:</b> Causes much inconvenience (i.e. traffic jams, loss of power, delays).</p>	5	
5	Economic Loss (Effect of implementing the project on local economy)	<p><b>5- Minimal:</b> Economic loss has little effect during the project.</p> <p><b>3- Moderate:</b> Economic loss (minimal disruption).</p> <p><b>1- Significant:</b> Economic loss (businesses closed, jobs affected).</p>	5	
6	Number of People to Benefit	<p><b>5- High:</b> More than 20,000</p> <p><b>3- Medium:</b> 4,000 –20,000</p> <p><b>1- Lower:</b> Fewer than 4,000</p>	5	

Cost			Score	For LMS WG only
1	Initial Cost	<p><b>5- Low:</b> \$0 to \$250,000</p> <p><b>3- Moderate:</b> \$251,000 to \$1 million</p> <p><b>1- High:</b> More than \$1 million</p>	5	
2	Maintenance /Operating Costs	<p><b>5- Lower costs:</b> Less than 5% per annum of the initial cost.</p> <p><b>3- Moderate:</b> 5%-10% per annum of the initial cost.</p> <p><b>1- High:</b> More than 10% per annum of the initial cost.</p>	3	
3	Environmental Cost Impact	<p><b>5- Positive effect</b> on the environment.</p> <p><b>3- No effect</b></p> <p><b>1- Adverse effect</b> on the environment.</p>	3	
4	Financing Availability	<p><b>5- Good:</b> Readily available with grants and/or matching funds</p> <p><b>3- Moderate:</b> Limited matching funds available</p> <p><b>1- Poor:</b> No funding sources or matching funds identified</p>	5	
5	Repetitive <u>FLOOD</u> damages corrected (applies ONLY to NFIP-insured structure(s) w/two paid flood losses).	<p><b>5- High:</b> Resolves repetitive loss</p> <p><b>3- Medium:</b> Repetitive loss mitigation possible, but not documented.</p> <p><b>1- Low:</b> Little effect on repetitive loss.</p> <p><b>N/A:</b> Not a NFIP insured structure</p>	N/A	

## PART II

### *Benefit Cost Analysis – QUICK WORKSHEET*

This worksheet to be filled out by the applicant, is designed for Local Mitigation Strategy Working Group use only. This gives the group a flavor for the potential benefits a particular project may yield. Here's your chance to quantitatively make the case for your project as COST EFFECTIVE. This BCA is not the same one as the FEMA BCA. The FEMA BCA requires a lot more detail, but this one will help you to further develop the "official FEMA BCA" should your project go forward as a FEMA grant request.

ESTIMATED COST OF THE PROJECT: \$110,000

---

DESCRIBE THE COSTS ASSOCIATED WITHOUT THIS MITIGATION PROJECT:

---

Some possible costs are:

Real Property Losses:	<u>\$180,000</u>
Furnishing/Equipment Losses:	<u>\$105,000</u>
Alternate facility costs:	<u>\$28,000</u>
Contract/rental costs:	<u>\$26,000</u>

Other associated costs (list):

<u>Cost of not providing essential</u>	<u>                    </u>
<u>Emergency communications</u>	<u>                    </u>
<u>For Fire, EMS, and CCSO within</u>	<u>                    </u>
<u>The community...This is difficult to quantify, but it's very expensive...</u>	<u>                    </u>

**Total Cost for Future Damages & Associated Expenses:**

**\$339,000** (NOTE: This figure should be detailed above.)

Statement to support above costs/losses: Interior damage to structures without proper humidification components to affect furnishings and advanced information technology equipment. The cost to relocate personnel and apparatus to appropriate facilities with emergency power is expensive, coupled with the cost to rent properly sized generators to operate fire full-service stations.

---



---



---

**DAMAGE & LOSS COSTS, divided by PROJECT COST = QUICK BCA RATIO**

$$\frac{\text{DAMAGES } (\$339,000)}{\text{PROJECT } (\$114,000)} = \text{BCA } 2.958$$



GREATER NAPLES FIRE RESCUE DISTRICT  
BOARD OF FIRE COMMISSIONERS  
Action Item Worksheet

**NEW BUSINESS**

**Agenda Item:** III. D.  
**Subject:** FM Global Fire Prevention Grant Program  
**Meeting Date:** February 13, 2018  
**Prepared By:** Shawn Hanson, Deputy Chief

**Background**

The 2018 FM Global Fire Prevention Grant Program has been opened and will close on March 31 at 5pm EST. Qualifying fire departments and organizations are those that will focus the grant funding on public fire prevention efforts. In 2017, the FM Global Fire Prevention Grant Program provided applicants with a \$2300 per award average.

The purpose of the FM Global Fire Prevention Grant Program is to support fire departments and organizational efforts aimed at promoting fire prevention and safeguarding of the public and firefighters through activities aimed at reaching high-risk target groups and mitigate incidences of deaths and injuries caused by fire and fire-related hazards.

Within the FM Global Fire Prevention Grant Program application, efforts will be focused on supporting the Districts Community Outreach Initiatives, including producing wildland fire and general fire safety education mail-outs for all of the Greater Naples citizenry.

The grants will be awarded on a competitive basis with an anticipated funding selection date of July 31, 2018.

STRATEGIC PLAN INITIATIVE: To support the District’s plan for enhancing its Insurance Service (ISO) through Community Risk Reduction efforts and outreach initiatives. (Strategy 2D)

**Funding Source/Financial Impact**

There is no financial impact to the District if awarded a FM Global Fire Prevention grant.

**Recommendation**

Staff’s recommendation is to proceed with the development and submittal of the FY2018 FM Global Fire Prevention Grant Program application for the purpose of supporting and enhancing the District’s ISO and Community Risk Reduction efforts.

**Potential Motion**

“I move to support Staff’s recommendation to submit an application for a FY2018 FM Global Fire Prevention Grant Program application to support and enhance the District’s ISO and Community Risk Reduction efforts.”

*Shawn Hanson*



**GREATER NAPLES FIRE RESCUE DISTRICT  
BOARD OF FIRE COMMISSIONERS  
Action Item Worksheet**

**NEW BUSINESS**

**Agenda Item:** III. E.  
**Subject:** 2018 FEMA Fire Prevention and Safety Grant Program  
**Meeting Date:** February 13, 2018  
**Prepared By:** Shawn Hanson, Deputy Chief

**Background**

The FY2017 FEMA Fire Prevention & Safety (FP&S) Grant Program application period was announced it will open on February 12 and will close on March 16 at 5pm EST. This year, FEMA has identified \$34.5 million in funding for qualifying fire service agencies.

The purpose of the FP&S Grant Program is to enhance the safety of the public and firefighters by promoting activities aimed at reaching high-risk target groups and mitigate incidences of deaths and injuries caused by fire and fire-related hazards.

Within the FP&S Grant application, Community Risk Reduction programs, including a fire safety trailer that will be utilized for home fire safety education, a door-to-door smoke alarm installation/education program that will be delivered to high risk facilities/populations, and other fire prevention education activities will be promoted, including wildland fire education.

The grants will be awarded on a competitive basis with an anticipated funding selection date of June 1, 2018. Period of performance is 12 months for grants awarded; the projected period of performance start date is August 1, 2018.

**STRATEGIC PLAN INITIATIVE:** To support the District’s plan for enhancing its Insurance Service (ISO) through Community Risk Reduction efforts and outreach initiatives. (Strategy 2D)

**Funding Source/ Financial Impact**

There is a 5% FEMA cost sharing requirement associated with the FP&S grant. The 5% District match will be met from Hurricane Irma Insurance Reimbursement funds already received from the destruction of the Safety Trailer (\$44,000). Funding for this grant, if approved will not exceed the following:

Fire Safety Trailer	\$160,300.00
Smoke Alarms w/10-year battery (includes hearing impaired alarms)	\$25,000.00
Public Education Materials and Supplies	<u>\$24,500.00</u>
	\$209,800.00
<b>5% (District Share)</b>	<b>\$ 10,490</b>

*[Handwritten signature]*



**GREATER NAPLES FIRE RESCUE DISTRICT  
BOARD OF FIRE COMMISSIONERS  
Action Item Worksheet**

**NEW BUSINESS**

**Agenda Item:** III. E.  
**Subject:** 2018 FEMA Fire Prevention and Safety Grant Program  
**Meeting Date:** February 13, 2018  
**Prepared By:** Shawn Hanson, Deputy Chief

---

**Recommendation**

Staff's recommendation is to proceed with the development and submittal of the FY2017 FEMA Fire Prevention and Safety Grant application to enhance the District's ISO and Community Risk Reduction efforts.

**Potential Motion**

"I move to support Staff's recommendation and submit an application for a FY2017 FEMA Fire Prevention and Safety Grant application to enhance the District's ISO and Community Risk Reduction efforts."



GREATER NAPLES FIRE RESCUE DISTRICT  
BOARD OF FIRE COMMISSIONERS  
Action Item Worksheet

NEW BUSINESS

**Agenda Item:** III. F.  
**Subject:** Knox Key Secure Program  
**Meeting Date:** February 13, 2018  
**Prepared By:** Shawn Hanson, Deputy Chief

**Background**

The purpose of transitioning to Knox products is to provide the Greater Naples stakeholders with a UL Listed product line that allows code compliance options not currently available from other vendors, and to institute a stronger accountability/tracking system through the utilization of the Knox KeySecure units.

The HomeBox program is a nationally advertised and requested Residential KnoxBox program that is available to the Greater Naples community. Additional products that will be available will include Fire Department Connection (FDC) locking caps, Elevator Box, Commercial KnoxBox, Gate & Key Switches, Standpipe Lock, Remote Power Box, Padlocks, Key Control, and a Document Cabinet for the storage of facility keys, fire alarm documents and pre-fire plans.

The current key retention boxes utilized in the apparatus today are limited by size and lack of technology; they are able to secure two keys, whereas the District has five, and tracking is limited to daily shift checks. The advantages of the KeySecure units are that they will provide for the securing of all of the District keys and neighboring fire district keys, and provide an individualized key retention tracking system through the utilization of individual User pin codes. Additionally, the KeySecure unit contains two alert LEDs indicating the key has not been replaced, and records up to 16,000 audit trails; all of which reduce the District's liability.

Providing the KeySecure units at no cost or at a reduced cost has been offered to the District by Knox to assist in ensuring the apparatus keys are secure prior to implementing the full product line of options. A similar agreement was utilized by a fire department in Illinois with great success and one has been offered to another fire department in Florida. It is anticipated this may become a more frequently offered opportunity to other fire departments.

**STRATEGIC PLAN INITIATIVE:** To support the District's strategy for implementing practices that enhance the professional quality of services the District provides to the Greater Naples community. (Strategy 2)

A handwritten signature in blue ink, appearing to read "Shawn Hanson".



GREATER NAPLES FIRE RESCUE DISTRICT  
BOARD OF FIRE COMMISSIONERS  
Action Item Worksheet

**NEW BUSINESS**

**Agenda Item:** III. F.  
**Subject:** Knox Key Secure Program  
**Meeting Date:** February 13, 2018  
**Prepared By:** Shawn Hanson, Deputy Chief

---

**Funding Source/Financial Impact**

The financial impact to the District would not be realized until FY2018-2019, with the opportunity for the cost to be reduced or neutralized dependent upon the volume of product procured by the community. The maximum financial impact is \$32,435.

**Recommendation**

Staff's recommendation is to proceed with the terms within the Knox letter dated January 23, 2018 and move forward with a comprehensive Knox program, including the KeySecure units to be utilized in frontline apparatus and support vehicles.

**Potential Motion**

"I move to support Staff's recommendation and accept the KeySecure units and terms as noted in the January 23, 2018 Knox letter, thereby enhancing the professional service options provided to the Greater Naples community."



January 23, 2018

Greater Naples Fire Rescue  
Chief Schuldt  
2700 Horseshoe Drive N  
Naples, FL 34104

Dear Chief Schuldt:

On behalf the entire team at Knox, I want to wish you a warm welcome to the Knox program. My team is excited to begin the official onboarding process for the Greater Naples Fire Department.

To summarize the understanding between our two organizations and move forward with the execution of Greater Naples program, Knox and Greater Naples Fire Rescue have agreed to the following special terms and conditions in order to ensure the establishment of a Knox program supported and protected by Knox KeySecure™. The terms of this special program are as follows:

1. Knox agrees to provide Greater Naples Fire Rescue with 65 KeySecure® 5 dual keyed units (Knox Model KSM-200K2), 65 KeySecure® Mounting Brackets (Knox Model Number KLS-MB-60/90) and the cloud based Administrative Software license for three years. (SMS-1000C3)
2. Upon shipment of the items outlined in item 1 above, an invoice will immediately be issued to Greater Naples Fire Department in the amount of \$32,435 /net 548 days.
3. Greater Naples Fire Department along will support the marketing efforts to the commercial and government establishments, between February 1, 2018 and August 1, 2019 to secure Knox Program Sales of \$250,000 which will include all of the Knox Products.
4. The Greater Naples Fire Department will support Knox's outreach efforts of the Knox Programs in Naples, FL as well as support the training of necessary department personnel.



5. If, during the course of the 18-month period (Feb 1, 2018 - August 1, 2019), Greater Naples Fire decides for any reason to end the program with Knox, Greater Naples will pay Knox in full for all KeySecure devices.
6. In the event the predicted purchases from the Greater Naples area fail to materialize, Knox Company will charge a *pro-rated* amount of the invoice based on #3 above.

The Knox Company is committed to making this as smooth and simple a transition to an active Knox program as possible for both the Fire and EMS service as well as businesses and individuals installing and utilizing Knox equipment.

Again, welcome to the Knox family and thank you for your support of our KnoxBox® Rapid Access System. If you have additional questions or concerns, please do not hesitate to reach out to your Knox Senior Regional Account Manager, Wendy Fecteau.

Warmest regards,

Knox Company



Joni Trempala  
CEO and President

cc: Josh Levine, Director of Sales  
Wendy Fecteau, Senior Regional Account Manager  
Susan Sornsin, Director of Finance

Knox Rapid Access System security is enhanced with the KeySecure 5, the latest master key retention that is heightened with new security and support capabilities. The KeySecure 5 device leverages Knox technology to provide secure, rapid access when seconds matter.

The Knox Master Key(s) is secured in a visible position providing immediate accountability and access. It holds up to two keys for shared system support. The KeySecure 5 maintains a history of unit activity including when and who released the key. With KeySecure 5, all administrative functions may be performed remotely or from a central office using KnoxConnect™ Management System. Admins communicate with KeySecure 5 using either WiFi or Ethernet connectivity or directly to a PC via the USB port to pull audit trails and update KeySecure device.



## PRODUCT SPECIFICATIONS

**Operating Temperature:** -20° to +60° C

**Storage Temperature:** -40° to +80°C

**Power:** Vehicle 7-amp 12-volt DC power supply or AC adapter 7-amp 12-volt

**Initial Power Stabilization Time:** Up to 5 seconds

**Construction:** Die-casted zinc

**Product Weight:** 7.6 lbs.

**Product Dimension:** 6.0"H x 4-1/4"W x 3-1/2 D

**Product with WiFi Antenna:** WiFi antenna extends an additional 1-1/2" from side of unit and adds up to 4-1/4" above the unit when oriented upwards

**Finish:** Powder coating

## FEATURES

- ✓ Secures 1 or 2 mechanical keys
- ✓ KnoxConnect Management System: Connect to KnoxConnect via Cloud (WiFi or Ethernet) or Local (USB port)
- ✓ Stores up to 5,000 User PIN codes
- ✓ Records up to 16,000 audit trail events
- ✓ User configuration and access activity tracked by name, date and time
- ✓ Access key using 4-6 digit PIN code
- ✓ Tamper monitor, with or without 12v power
- ✓ Keypad illuminates for day or night visibility
- ✓ 2 alert LEDs
- ✓ Can hold a Knox FDC Keywrench

## BENEFITS

- ✓ Reduces liability of lost keys
- ✓ Leverages KnoxConnect to configure devices, manage users and retrieve audit trail information
- ✓ Provides ability to secure and support shared systems
- ✓ Manages accountability, recording key releases
- ✓ Network-enabled, can connect to PC via a WiFi or Ethernet network to collect device history and program user access

## OPTIONS

- ✓ Cloud or Local-based KnoxConnect Management System
- ✓ 60°, 90°, or flat-mount bracket

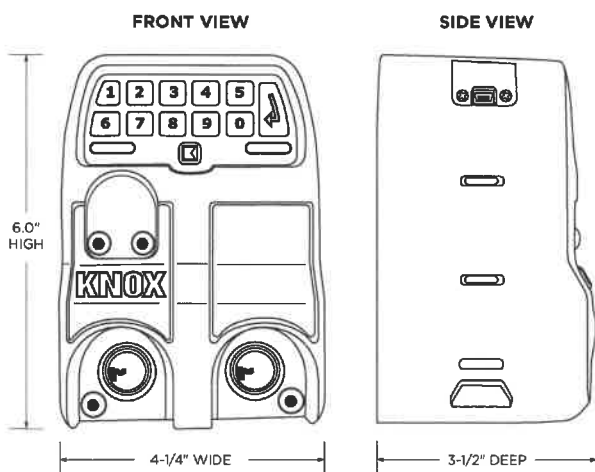

Knox recommends using and installing a Knox manufactured bracket. Three types of mounting brackets specifically made for the KeySecure 5 are available: a 60° angle, a 90° angle, and a flat mount bracket. These solid steel brackets can be used for installing the KeySecure units in a vehicle or office.

### FLAT MOUNT BRACKET

When mounting to a wall or panel, a flat mount bracket is recommended to mount a KeySecure unit with the proper clearances for power and Ethernet connections.

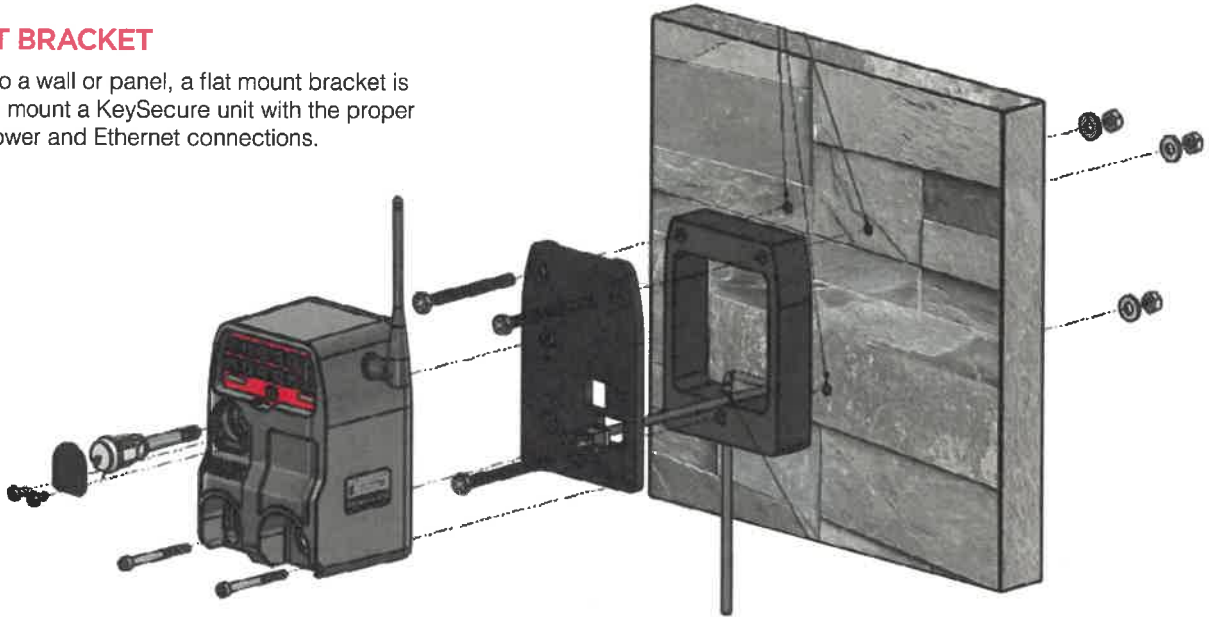

### 60 AND 90 DEGREE MOUNTING BRACKETS

The 60° & 90° brackets have the same vehicle mounting bolt pattern as the KeySecure 3b and 4. Both can be used to mount the KeySecure in a vehicle or office. Brackets can accommodate multiple orientations of KeySecure 5.

## ABOUT KNOX COMPANY

Over forty years ago, a unique concept in rapid access for emergency response was born. The Knox-Box<sup>®</sup>, a high-security key lock box, was designed to provide rapid access for emergency responders to reduce response times and protect property from forced entry.

Today, one revolutionary lock box has grown into a complete system providing rapid access for public safety agencies, industries, military, and property owners across the world. The Knox<sup>®</sup> Company is trusted by over 14,000 fire departments, law enforcement agencies, and governmental entities.

**KNOX COMPANY**  
1601 W. DEER VALLEY RD  
PHOENIX, AZ 85027

T. 800.552.5669  
F. 623.687.2290

**KNOXBOX.COM**  
INFO@KNOXBOX.COM



**NEW BUSINESS**

**Agenda Item:** III. G.  
**Subject:** Post Fire On-Scene Decontamination Kits  
**Meeting Date:** February 13, 2018  
**Prepared By:** Rob Low, Deputy Chief

**Background**

The Florida Legislature appropriated \$1,000,000 from the Insurance Regulatory Trust Fund in Specific Appropriation 2362 to the Department of Financial Services, Division of State Fire Marshal (the "Division"). The appropriation language directs the Division to administer a local government grant program and develop guidelines for the review and approval of grant proposals. The Division must consider the size and resources of the local government requesting funds and the local government's current capacity to adequately equip its firefighters.

The purpose of the grant program is for the purchase of protective clothing, self-contained breathing apparatus, and other personal protective equipment for firefighters in order to mitigate exposure to hazardous, cancer-causing chemicals and to protect the health and safety of Florida firefighters, pursuant to section 633.520, Florida Statutes (F.S.).

With the intent of maximizing the number of state firefighters eligible to benefit under the program, the Division is accepting proposals for the awarding of Post Fire On-Scene Decontamination Kits (hereafter, referred to individually as a "Kit"). The purpose of these Kits is to mitigate firefighters' exposure to hazardous, cancer-causing products of combustion, thus protecting the health and safety of firefighters. Each applicant determined to be eligible for an award under the first round will be awarded at least one (1) Kit for each pumping apparatus. The District has applied for 50 kits valued at \$75-\$100 per kit.

**Funding Source/Financial Impact**

The grant program conditions described will require a total cost sharing of 0% of the total award.

**Recommendation**

If selected as a recipient, approve staff to take possession and distribute the Kit(s) to appropriate fire apparatus.

**Potential Motion**

"I move to support Staff's recommendation to take possession of the Kit(s) if awarded and distribute to appropriate fire apparatus.

*[Handwritten signature]*



**GREATER NAPLES FIRE RESCUE DISTRICT  
BOARD OF FIRE COMMISSIONERS  
Action Item Worksheet**

**NEW BUSINESS**

**Agenda Item:** III. H

**Subject:** Internship

**Meeting Date:** February 13, 2018

**Prepared By:** Nicole Chesser, Executive Assistant

**Background**

Since establishment of the District there has not been a staff position to address Communications and Public Affairs needs. As part of the District's efforts to expand these necessary services while responsibly managing the budget staff has identified a program that will support this need and the District's mission without negatively impacting the current budget.

The Collier County Public Schools currently offers career academies to provide students with the skills and experience to learn different career themes such as Finance, Hospitality & Tourism, Information Technology, Engineering, and Health Sciences. The Greater Naples Chamber of Commerce has partnered with the schools to provide local businesses with Interns from the Academy Program.

There are many administrative tasks, especially in the area of public information that could be assigned to an Intern that will assist in increasing administrative staff productivity while helping students gain valuable work experience.

The District specifically seeks an intern to support efforts in developing community outreach materials, internal newsletters, annual reports, and management of various social media platforms that serve to maintain contact with the community.

**Funding Source/Financial Impact**

The student is required to complete a minimum of 120 paid work hours during their time as an intern. The standard minimum pay for an intern is minimum wage at \$8.10 per hour or \$972.00 total. The Greater Naples Chamber of Commerce in cooperation with the Community Foundation has agreed to provide a \$1,000.00 grant to cover this expense.

**Recommendation**

Support the District's participation in the internship program.

**Potential Motion**

I move to support the District's participation in the internship program.

A handwritten signature in blue ink, appearing to read "Ryan O. Pardo", written over a horizontal line.

# WHY INTERNS?

Now more than ever, internships and other work-based learning opportunities, serve as a critical component to developing the future workforce in Collier County. These opportunities engage, prepare, and retain local talent! Interns instantly add value to the culture, perspective, and productivity of any size business or organization.

## BENEFITS FOR BUSINESSES

- Create an ongoing pipeline of future employees
- Support the local community by enhancing workforce development
- Efficient way to “test drive” talent
- Fresh perspective and ideas
- Increase productivity through short term support

## BENEFITS FOR STUDENTS

- Gain authentic work experience
- Expand their network and form new relationships
- Learn new technology
- Develop communication skills
- Strengthen their resume

## HOW WE SUPPORT

- One on one support during initiation of internship implementation
- Assistance with finding high quality candidates for the position
- Business toolkits with FAQs, Guides for postings, time-lines, sample check-in reports, and more!



## ADDITIONAL WORK-BASED LEARNING OPPORTUNITIES

- Host a Job Shadow
- Provide a mock interview
- Become a mentor
- Participate in a presentation panel
- Host a work-site tour
- Participate in an informational interview
- Conduct a virtual tour

## CONTACT:

**Davina Hartsfield**, LCF Internship Coordinator  
Davina@napleschamber.org  
Office 239.403.2912



*“By participating as a business partner our intention is to plant seeds of inspiration with our student interns who are about to enter college, trade school, or the work force, expose them to a professional work environment, and help them find their passion. Then we let the world nourish and grow the students and hope the fruits they bear come back to feed our local businesses, economy, and community.”*

*–Melissa Griffith, Thomas Riley Artisans Guild*